

Benelli

WORKSHOP MANUAL

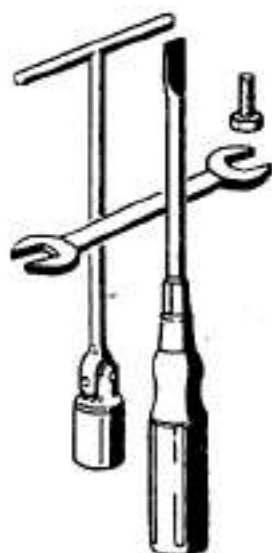

MOTORELLA «78»
G2 with pedals
G2 elle
G2 KS
MAGNUM 3V «78»
EXPORT 3V «78»
50 TURISMO
50 MAGNUM
50 CROSS «76»
125 TURISMO
125 ENDURO

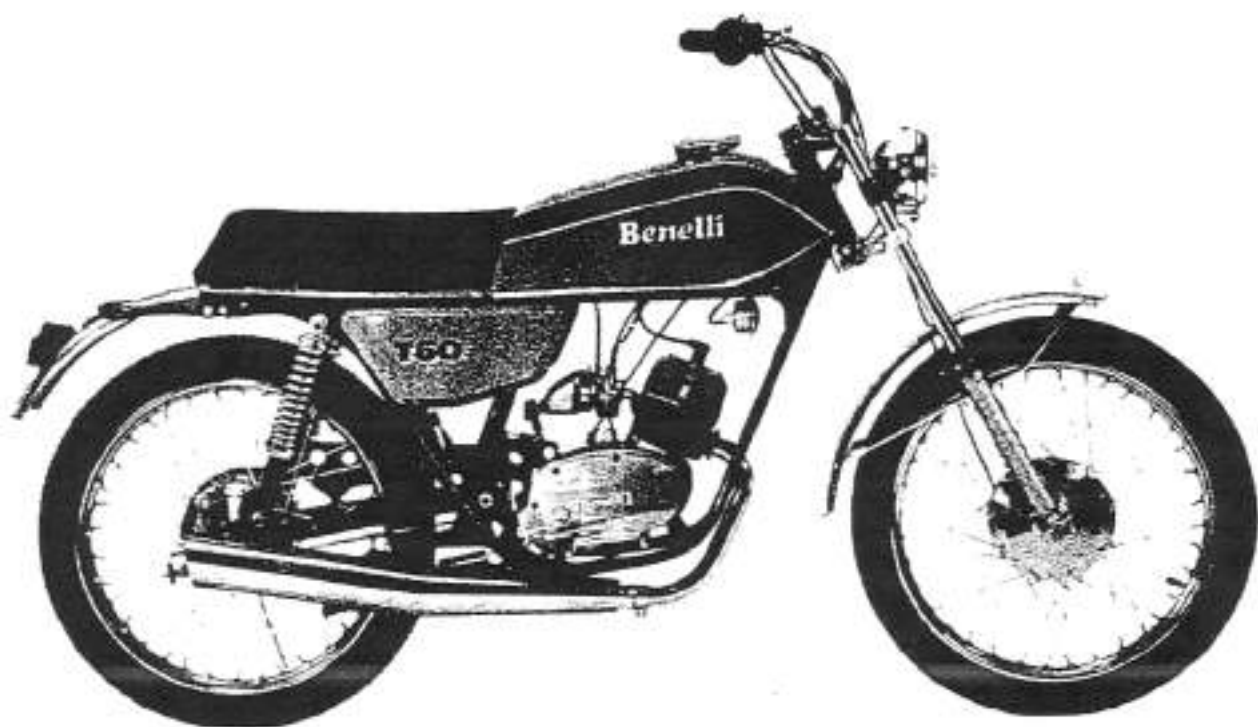

50 TURISMO



50 MAGNUM



MAGNUM 3V



EXPORT 3V 78



G2 Elle



G2 KS



MOTORELLA



G2 with pedals



50 CROSS '76



125 TURISMO



125 ENDURO

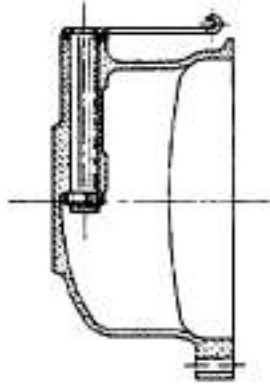

SECTION A-B

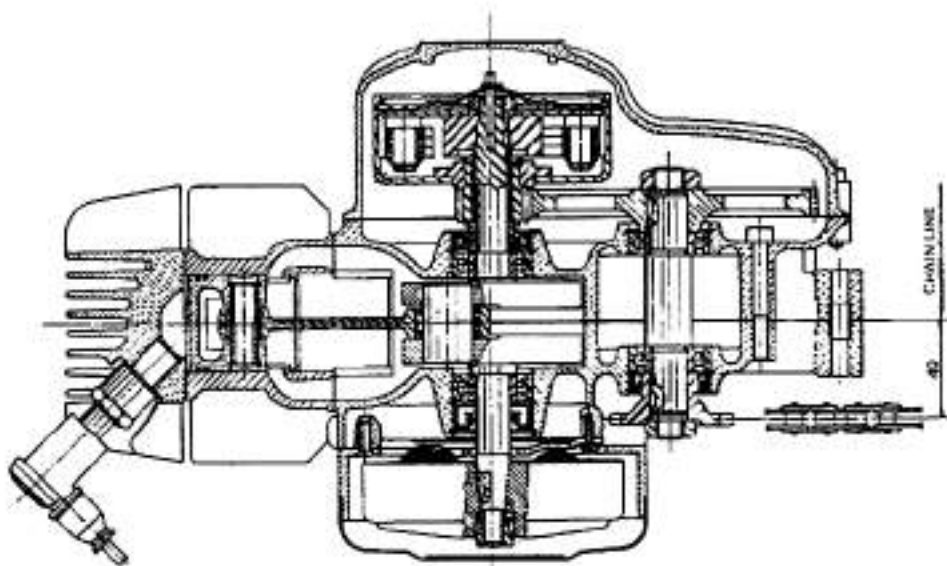
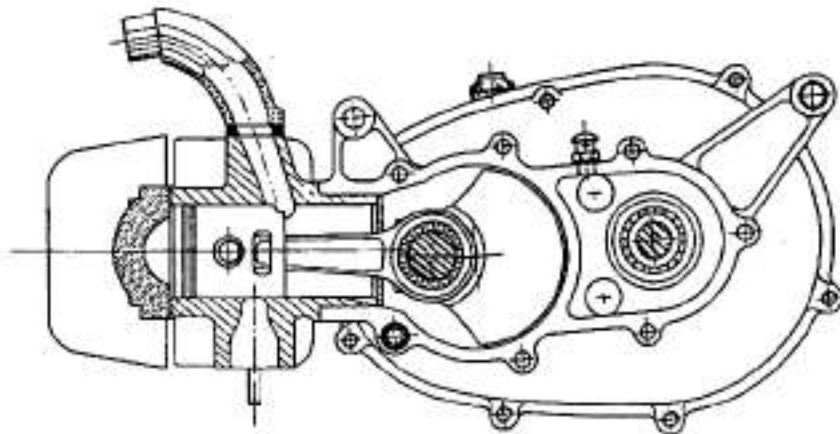
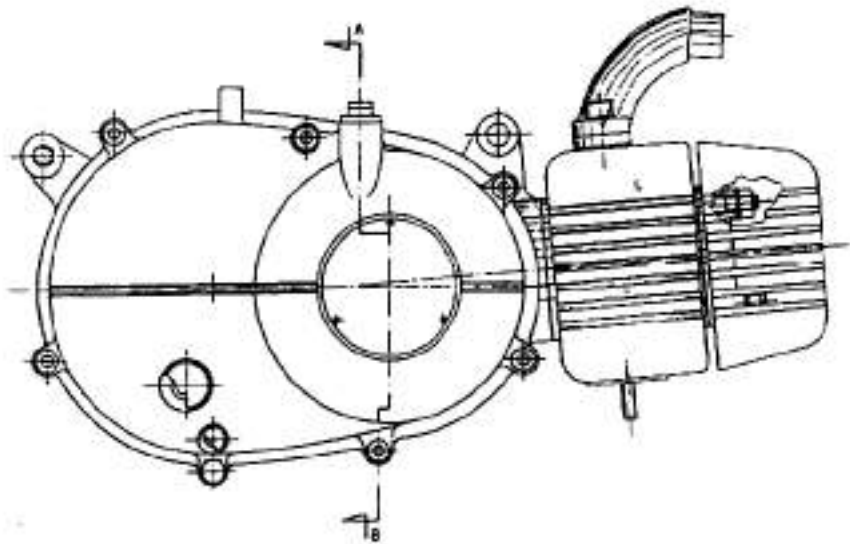

ENGINE «G2 with pedals»

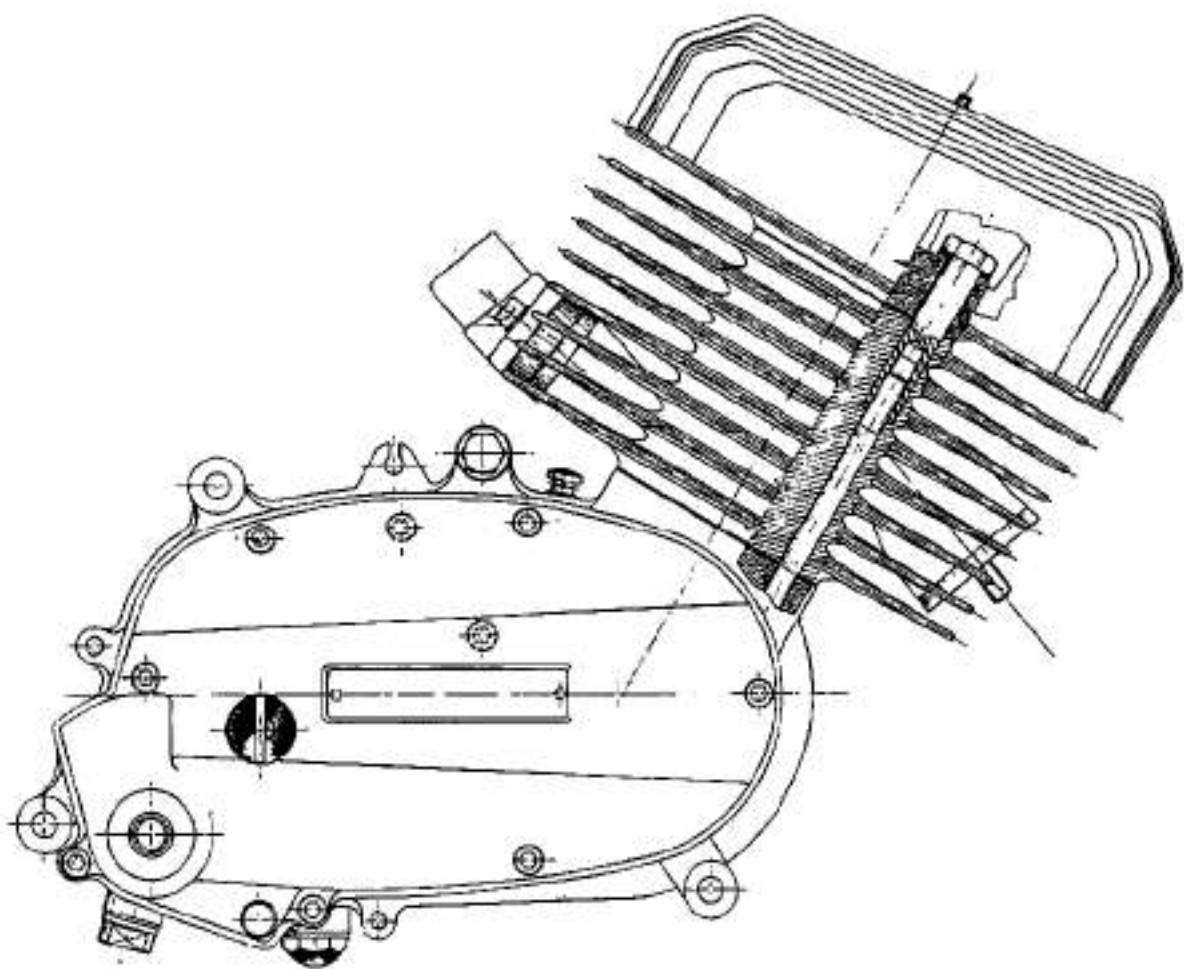
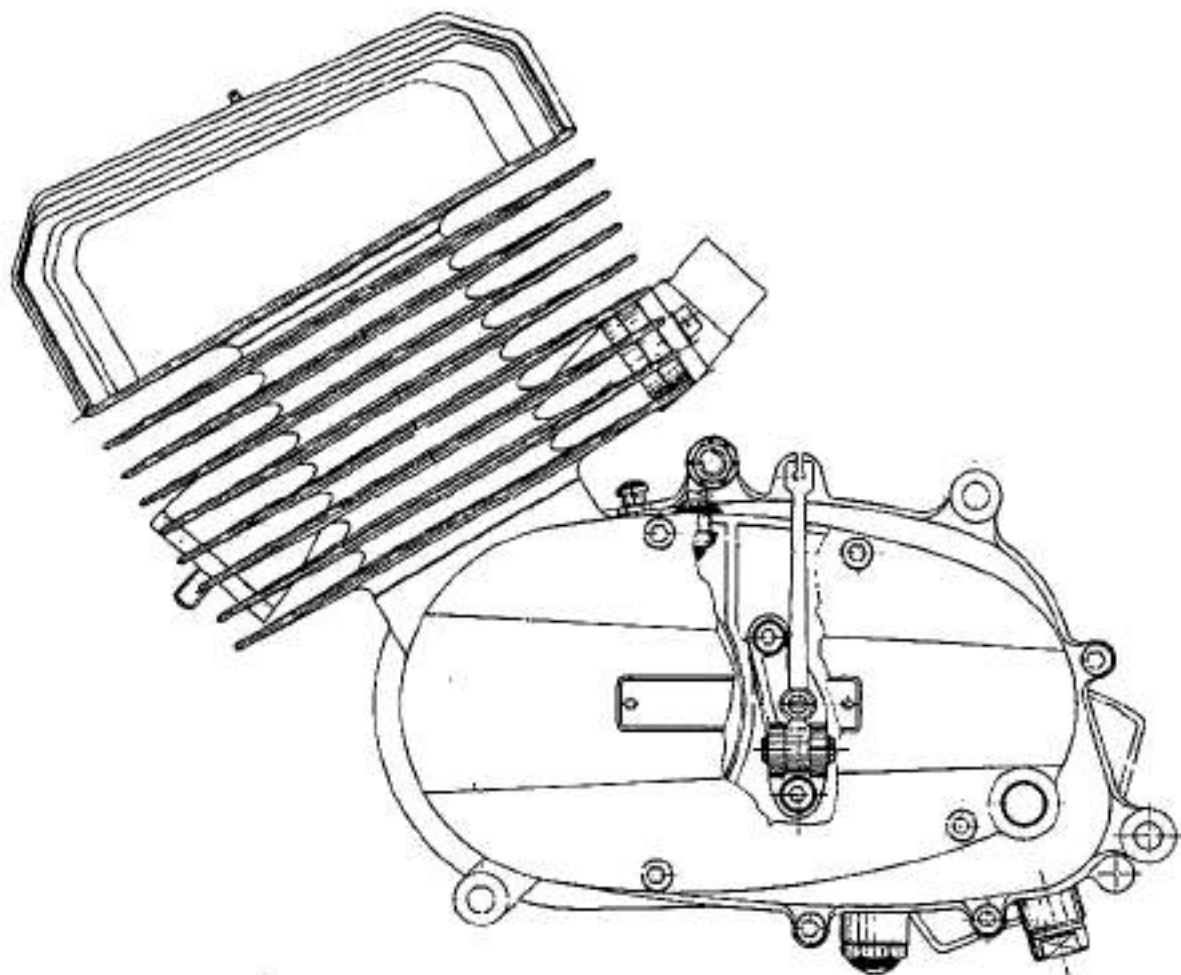

ENGINE 125 TURISMO - 125 ENDURO

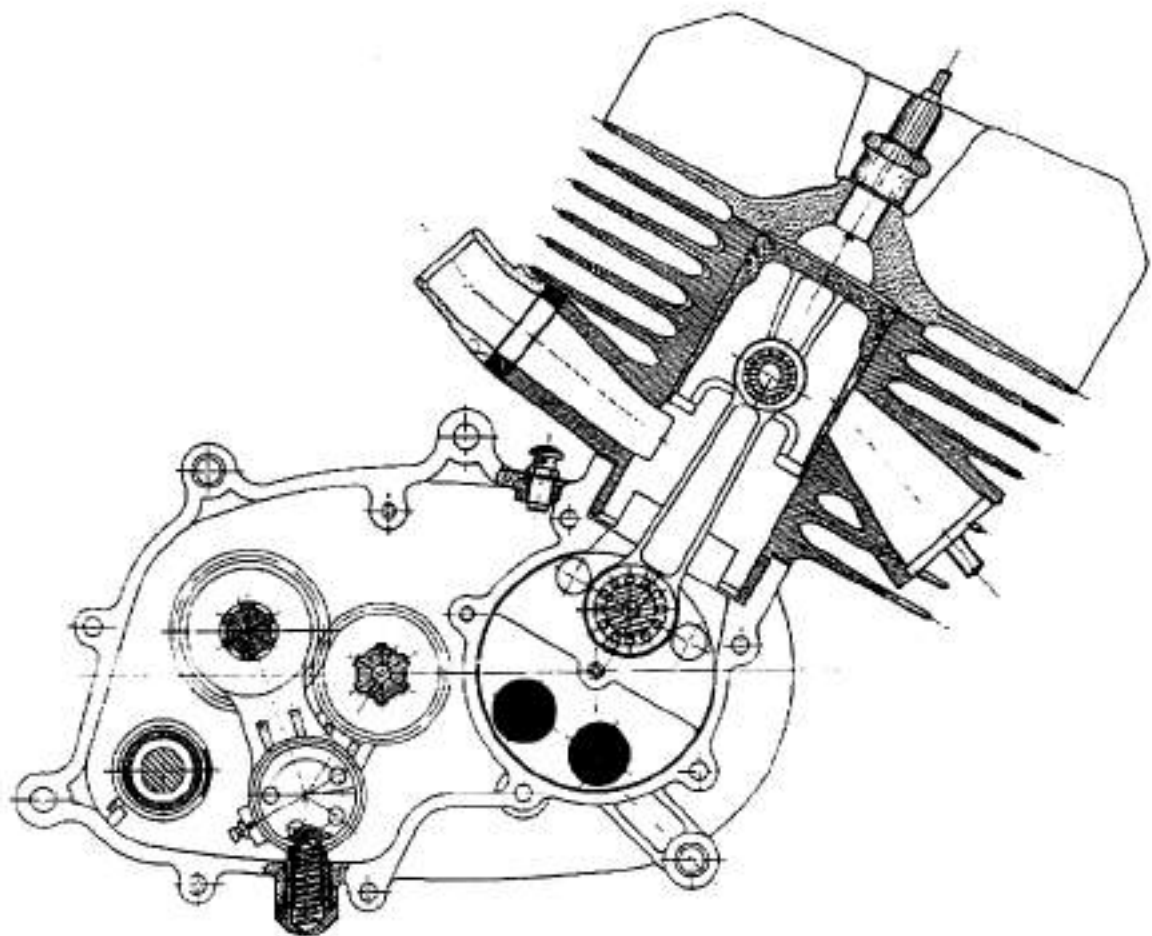
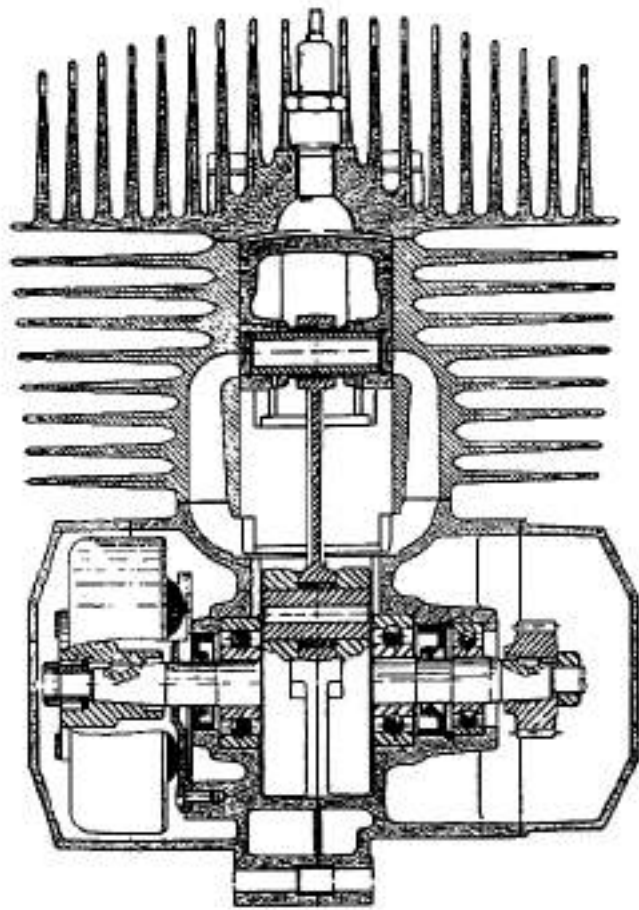

ENGINE 125 TURISMO · 125 ENDURO

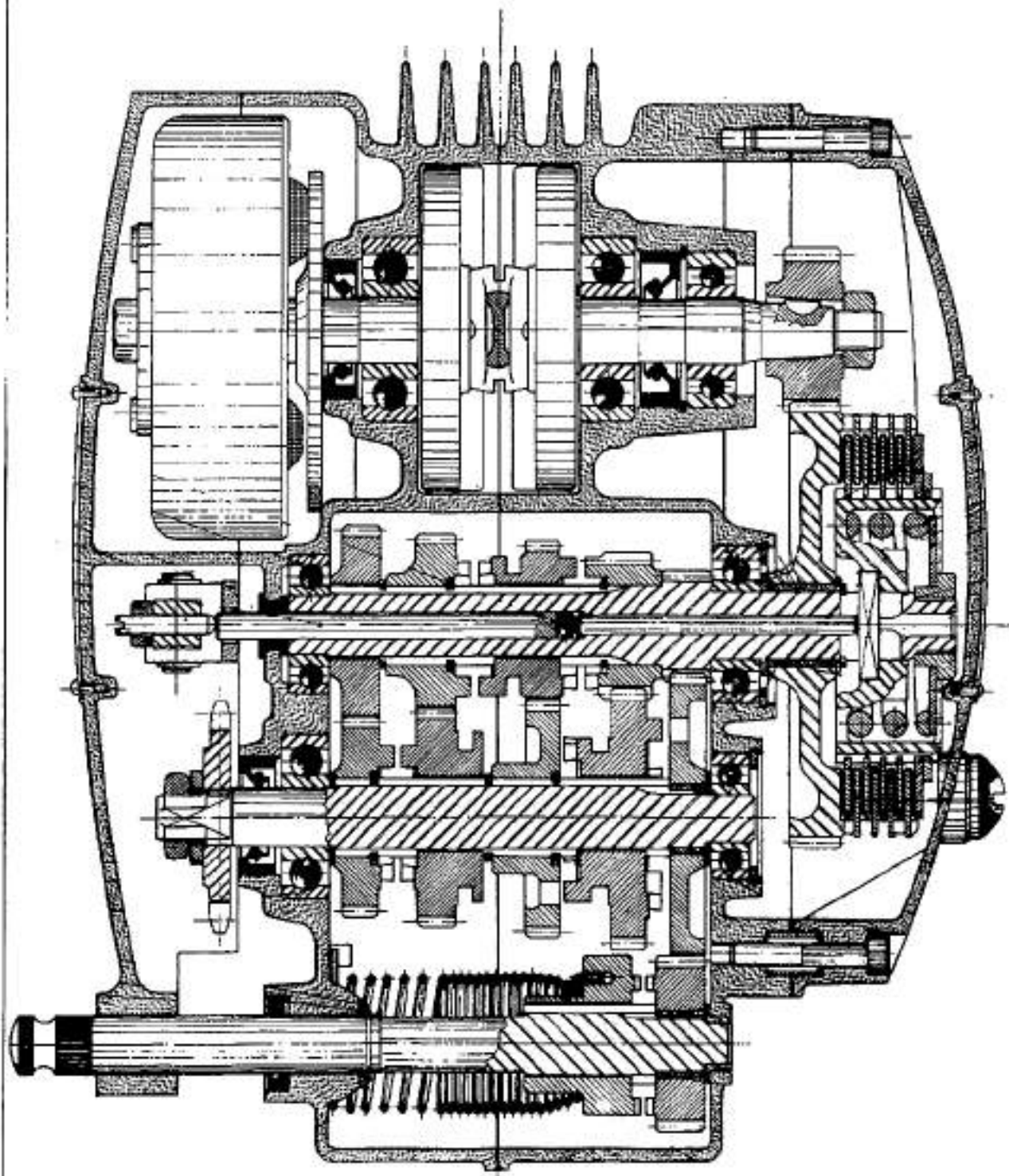

ENGINE 125 TURISMO - 125 ENDURO

INDEX

1 IDENTIFICATION DATA page 116

- 1.1 Spare parts
- 1.2 Warranty

2 MAIN FEATURES page 116

- 2.1 Motorella
- 2.2 G2 with pedals
- 2.3 G2 Elle-G2 KS
- 2.4 Magnum 3V
- 2.5 Export 3V
- 2.6 50 Turismo
- 2.7 Cross
- 2.8 Magnum
- 2.9 125 Turismo
- 2.10 125 Enduro

3 CONTROLS AND ACCESSORIES page 216

- 3.1 Motorella
- 3.2 G2 with pedals
- 3.3 G2 Elle-G2 KS
- 3.4 Magnum 3V
- 3.5 Export 3V
- 3.6 50 Turismo
- 3.7 Cross
- 3.8 Magnum
- 3.9 125 Turismo
- 3.10 125 Enduro

4 MAINTENANCE AND LUBRICATIONS page 316

5 INSTRUMENTS AND CONTROLS page 416

- 5.1 Gearshift pedal
- 5.2 Easy starter lever for 125 Turismo and 125 Enduro
- 5.3 Engine stop button - 125 Turismo
- 5.4 Steering lock
- 5.5 Fuel tap
- 5.6 Lights switch, horn, engine stop button - Motorella - G2 with pedals - G2 KS - Export 3V - Magnum 3V - Magnum - 50 Turismo - Cross
- 5.7 Lights switch, horn, turn signals switch - 125 Enduro
- 5.8 Turn signals switch - 125 Turismo
- 5.9 Horn - 125 Turismo
- 5.10 Lights switch - 125 Turismo

6 ADJUSTMENTS page 516

- 6.1 Motorella - G2 KS - G2 with pedals - Export 3V - Magnum 3V

- 6.2 50 Turismo - Cross - Magnum
- 6.3 125 Turismo - 125 Enduro

7 SPECIFIC TOOLS page 46

8 ENGINE OVERHAULING page 48

- 8.1 Motorella - G2 with pedals - G2 Elle - G2 KS - Export 3V - Magnum 3V
- 8.2 Cross - Magnum - 50 Turismo - 125 Turismo - 125 Enduro

9 GEARBOX page 54

- 9.1 Stripping the gearbox
- 9.2 Stripping the shafts: mainshaft, layshaft and splined shaft complete with the crankcase halves, right
- 9.3 Assembly

10 VALVE GEARING page 58

- 10.1 Timing diagram G2 KS - G2 Elle - G2 with pedals
- 10.2 Timing diagram Motorella
- 10.3 Timing diagram Export 3V - Magnum 3V
- 10.4 Timing diagram 50 Turismo - Cross - Magnum
- 10.5 Timing diagram 125 Turismo - 125 Enduro

11 CARBURATION page 60

- 11.1 Motorella - G2 KS - G2 Elle - G2 with pedals - 50 Turismo
- 11.2 125 Turismo - 125 Enduro

12 LUBRICATION page 64

- 12.1 Motorella - G2 with pedals - G2 Elle - G2 KS - Magnum 3V - Export 3V
- 12.2 50 Turismo - Cross - Magnum - 125 Turismo - 125 Enduro

13 ELECTRICAL EQUIPMENT page 68

- 13.1 Battery 125 Enduro
- 13.2 Ignition
- 13.3 Lighting system

14 WIRING DIAGRAMS page 70

- 14.1 G2 Elle
- 14.2 Motorella - G2 KS - G2 with pedals - Magnum 3V - Export 3V
- 14.3 50 Turismo
- 14.4 Cross
- 14.5 Magnum
- 14.6 125 Turismo
- 14.7 125 Enduro

1 IDENTIFICATION DATA (fig. 1)

Each motorcycle is identified by an identification number on the frame down tube and a number stamped on the engine crankcase.

The identification number on the frame is mentioned in the «Certificate of conformity» for Motorella, G2 with pedals, G2 Elle, G2 KS, Magnum 3V, Export 3V, 50 Turismo, 50 Cross, 50 Magnum, and in the motorcycle log-book for 125 Turismo, 125 Enduro and identifies the vehicle to all legal effects.

1.1 SPARE PARTS

In case of part replacements, ensure that «original Benelli spare parts» only are used.

The use of non-genuine parts invalidates every «WARRANTY» right.

1.2 WARRANTY

The warranty is valid for a period of 6 months from the delivery date of the vehicle to the direct buyer.

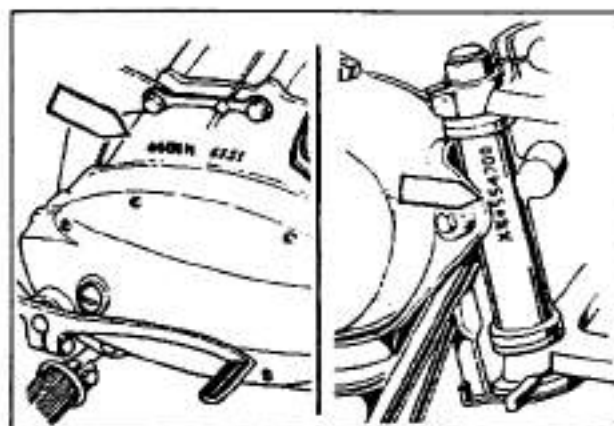

2.1 MOTORELLA 78

ENGINE

One cylinder - 2 stroke	
Bore	40 mm
Stroke	39 mm
Displacement	49 cc
Max output	1.3 HP at 4200 rpm
Compression ratio	8.5 to 1

FUEL

Petrol oil mixture, oil 4%

IGNITION

Magneto-flywheel/alternator (6V - 18W)

CLUTCH

Automatic centrifugal in oil bath

TRANSMISSIONS

Primary: by gears
 Ratio (engine-gearbox) = 1 to 3.18 (Z = 22/70)
 Secondary: by chain
 Ratio (pinion-crown gear) = 1 to 4.18 (Z = 11/46)
 Overall ratio (engine-wheel) = 1 to 13.3057

FRAME

Steel tubes and stamped plate.

SUSPENSIONS

Front: telescopic fork.
 Rear: swing arm with mechanical dampers.

WHEELS

Light alloy castings with rims: 10"

TYRES

Front and rear: 3.00x10".

BRAKES

Mechanical expanding type: front and rear hand controlled (levers on the handlebar: R/H side front brake, L/H side rear brake). Brake shoe dia. 90 mm, width 18 mm.

DIMENSIONS AND WEIGHT

Wheelbase (fully loaded)	960 mm
Max. length	1410 mm
Max. width	700 mm
Max. height	950 mm
Weight (dry)	43 kg

PERFORMANCES

Max speed: according to Italian road regulations.
 Consumption: 1,5 l x 100 km (CUNA).

FUEL AND OIL CAPACITIES

Fuel tank: 2.5 l petrol oil mixture «AGIP F.1 2T» oil 4%.
 Oil sump: 0.160 kg oil «AGIP F.1 Motoroil HD SAE 20W/30".

2.2 G2 WITH PEDALS

ENGINE	One cylinder - 2 stroke	
	Bore	40 mm
	Stroke	39 mm
	Displacement	49 cc
	Max output	1.37 HP at 4710 rpm
	Compression ratio	8 to 1
FUEL	Petrol oil mixture, oil 4%	
IGNITION	Magneto-flywheel/alternator (6V - 18W)	
CLUTCH	Automatic centrifugal in oil bath	
TRANSMISSIONS	Primary: by gears Ratio (engine-gearbox) = 1 to 4.285 (Z = 21/90) Secondary: by chain Ratio (pinion-crown gear) = 1 to 3.8 (Z = 12/46) Overall ratio (engine-wheel) = 1 to 16.4285	
FRAME	Steel tubes and stamped plate.	
SUSPENSIONS	Front: telescopic fork. Rear: swing arm with mechanical dampers.	
WHEELS	Front and rear: spoked rims: 1.35x16".	
TYRES	Front and rear: 2 1/4x16".	
BRAKES	Mechanical expanding type: front and rear hand controlled (levers on the handlebar: R/H side front brake, L/H side rear brake). Brake shoe dia. 90 mm, width 18 mm.	
DIMENSIONS AND WEIGHT	Wheelbase (fully loaded)	1080 mm
	Max. length	1640 mm
	Max. width	680 mm
	Max. height	970 mm
	Weight (dry)	45.5 kg
PERFORMANCES	Max speed: according to Italian road regulations. Consumption: 1.6 l x 100 km (CUNA).	
FUEL AND OIL CAPACITIES	Fuel tank: 2.5 l petrol oil mixture «AGIP E.1 2T» oil 4%. Oil sump: 0.110 kg oil «AGIP F.1 Motoroil HD SAE 20W/30".	

2.3 G2 ELLE - G2 KS

ENGINE	One cylinder - 2 stroke	
	Bore	40 mm
	Stroke	39 mm
	Displacement	49 cc
	Max output	1.36 HP at 4500 rpm
	Compression ratio	7.9 to 1
FUEL	Petrol oil mixture, oil 4%	
IGNITION	Magneto-flywheel/alternator (6V - 18W)	
CLUTCH	Automatic centrifugal in oil bath	
TRANSMISSIONS	Primary: by gears Ratio (engine-gearbox) = 1 to 3.18 (Z = 22/70) Secondary (pinion-crown gear) = 1 to 5.33 (Z = 9/48) Overall ratio (engine-wheel) = 1 to 16.968	
FRAME	Steel tubes and stamped plate.	
SUSPENSIONS	Front: telescopic fork. Rear: swing arm with mechanical dampers.	
WHEELS	Front and rear: spoked rims 1.35x16".	
TYRES	Front and rear: 2 1/4x16".	
BRAKES	Mechanical expanding type: front and rear hand controlled (levers on the handlebar: R/H side front brake, L/H side rear brake). Brake shoe dia. 90 mm, width 18 mm.	
DIMENSIONS AND WEIGHT	Wheelbase (fully loaded)	1090 mm
	Max. length	1620 mm
	Max. width	680 mm
	Max. height	1020 mm
	Weight (dry)	45 kg
PERFORMANCES	Max speed: according to Italian road regulations. Consumption: 2.2 l x 100 km (CUNA).	
FUEL AND OIL CAPACITIES	Fuel tank: 2.5 l petrol oil mixture «AGIP F.1 2T» oil 4%. Oil sump: 0.160 kg oil «AGIP F.1 Motorol HD SAE 20W/30".	

2.4 MAGNUM 3V

ENGINE	One cylinder - 2 stroke Bore 40 mm Stroke 39 mm Displacement 49 cc Max output 1.35 HP at 4810 rpm Compression ratio 8.9 to 1
FUEL	Petrol oil mixture, oil 3%
IGNITION	Magneto-flywheel/alternator (6V - 18W)
CLUTCH	Multiplate in oil bath, hand controlled with lever on L/H side of handlebar.
GEARBOX	3 speeds hand operated with twist grip on L/H side of handlebar. Gear ratios: 1st gear (Z = 16/53) = 1 to 3.313 2nd gear (Z = 24/45) = 1 to 1.875 3rd gear (Z = 31/38) = 1 to 1.226
TRANSMISSIONS	Primary (engine gearbox): by gears Ratio (Z = 21/75) = 1 to 3.571 Secondary (pinion-crown gear): by chain Ratio (Z = 12/33) = 1 to 2.750 Overall ratio (engine-wheel) = 1 to 12.040
FRAME	Tubular structure.
SUSPENSIONS	Front: telescopic fork. Rear: swing arm with mechanical dampers.
WHEELS	Front and rear: light alloy castings with rims 2.10x10".
TYRES	Front and rear: 3.50x10".
BRAKES	Mechanical expanding type. Front: hand controlled (brake shoe dia. 90 mm, width 18 mm); rear: foot controlled with pedal on the R/H side of the vehicle (brake shoe dia. 90 mm, width 18 mm).
DIMENSIONS AND WEIGHT	Wheelbase (fully loaded) 1025 mm Max. length 1500 mm Max. width 690 mm Max. height 950 mm Weight (dry) 45 kg
PERFORMANCES	Max speed: according to Italian road regulations. Consumption: 2.2 l x 100 km (CUNA).
FUEL AND OIL CAPACITIES	Fuel tank: 3 l petrol oil mixture «AGIP F 1 2T» oil 3% Oil sump: 0.360 kg oil «AGIP F.1 Motoroil HD SAE 20W/30".

2.5 EXPORT 3V

ENGINE	One cylinder - 2 stroke Bore 40 mm Stroke 39 mm Displacement 49 cc Max output 1 HP at 4815 rpm Compression ratio 8 to 1
FUEL	Petrol oil mixture, oil 3%
IGNITION	Magneto-flywheel/alternator (6V - 18W)
CLUTCH	Multiplate in oil bath, hand controlled with lever on the L/H side of handlebar.
GEARBOX	3 speeds hand operated with twist grip on L/H side of handlebar. Gear ratios: 1st gear (Z = 16/53) = 1 to 3.313 2nd gear (Z = 24/45) = 1 to 1.875 3rd gear (Z = 31/38) = 1 to 1.226
TRANSMISSIONS	Primary (engine gearbox): by gears Ratio Z = 21/75) = 1 to 3.571 Secondary (pinion-crown gear): by chain Ratio (Z = 12/33) = 1 to 2.750 Overall ratio (engine-wheel) = 1 to 12.040
FRAME	Tubular structure.
SUSPENSIONS	Front: telescopic fork. Rear: swing arm with mechanical dampers.
WHEELS	Front and rear: spoked rims 1.35x16".
TYRES	Front and rear: 2 1/4x16".
BRAKES	Mechanical expanding type. Front: hand controlled (brake shoe dia 90 mm, width 18 mm); rear: foot controlled with pedal on the R/H side of the vehicle (brake shoe dia. 90 mm, width 18 mm).
DIMENSIONS AND WEIGHT	Wheelbase (fully loaded) 1100 mm Max. length 1640 mm Max. width 690 mm Max. height 1030 mm Weight (dry) 45 kg
PERFORMANCES	Max speed: according to Italian road regulations. Consumption: 2.2 l x 100 km (CUNA).
FUEL AND OIL CAPACITIES	Fuel tank: 2.5 l petrol oil mixture «AGIP F.1 2T» oil 3% . Oil sump: 0.360 kg oil «AGIP F.1 Motoroil HD SAE 20W/30".

2.6 50 TURISMO

ENGINE	One cylinder - 2 stroke Bore 40 mm Stroke 39 mm Displacement 49 cc Max output 1.2 HP at 4200 rpm Compression ratio 8 to 1
FUEL	Petrol oil mixture, oil 3%
IGNITION	Magneto-flywheel/alternator (6V - 18W)
CLUTCH	Multiplate in oil bath, hand controlled with lever on L/H side of handlebar.
GEARBOX	5 speeds foot operated with pedal on R/H side of the vehicle. Gear ratios: 1st gear (Z = 16/48) = 1 to 3.000 2nd gear (Z = 23/42) = 1 to 1.826 3rd gear (Z = 27/38) = 1 to 1.407 4th gear (Z = 30/35) = 1 to 1.166 5th gear (Z = 33/32) = 1 to 0.969
TRANSMISSIONS	Primary (engine-gear box): by gears Ratio (Z = 21/71) = 1 to 3.38 Secondary (pinion-crown gear): by chain Ratio (Z = 11/45) = 1 to 4.090 Overall ratio (engine-wheel) = 1 to 13.395
FRAME	Cradle, tubular structure.
SUSPENSIONS	Front: telescopic fork. Rear: swing arm with mechanical dampers.
WHEELS	Front and rear: spoked rims WM 1/1.6x18"
TYRES	Front: 2.50-18" (MT 76) Rear: 2.50-18" (MT 53)
BRAKES	Mechanical expanding type. Front: hand controlled (brake shoe dia. 135.5 mm, width 24 mm); rear: foot controlled with pedal on the L/H side of the vehicle (brake shoe dia. 122.5 mm, width 19 mm).
DIMENSIONS AND WEIGHT	Wheelbase (fully loaded) 1220 mm Max. length 1825 mm Max. width 750 mm Max. height 990 mm Weight (dry) 78 kg
PERFORMANCES	Max speed: according to Italian road regulations. Consumption: 2.75 l x 100 km (CUNA).
FUEL AND OIL CAPACITIES	Fuel tank: 10.5 l petrol oil mixture «AGIP F.1 2T» oil 3%. Oil sump: 0.500 kg oil «AGIP F 1 Motoroil HD SAE 20W/30"».

2.7 CROSS

ENGINE	One cylinder - 2 stroke Bore 40 mm Stroke 39 mm Displacement 49 cc Max output 1.3 HP at 4800 rpm Compression ratio 8 to 1
FUEL	Petrol oil mixture, oil 3%
IGNITION	Magneto-flywheel/alternator (6V - 18W)
CLUTCH	Multiplate in oil bath, hand controlled with lever on L/H side of handlebar.
GEARBOX	5 speeds foot operated with pedal on R/H side of the vehicle. Gear ratios: 1st gear (Z = 16/48) = 1 to 3.000 2nd gear (Z = 23/42) = 1 to 1.826 3rd gear (Z = 27/38) = 1 to 1.407 4th gear (Z = 30/35) = 1 to 1.166 5th gear (Z = 33/32) = 1 to 0.969
TRANSMISSIONS	Primary (engine-gear box): by gears Ratio (Z = 21/71) = 1 to 3.38 Secondary (pinion-crown gear): by chain Ratio (Z = 11/46) = 1 to 4.182 Overall ratio (engine-wheel) = 1 to 13.710
FRAME	Cradle, tubular structure.
SUSPENSIONS	Front: telescopic fork. Rear: swing arm with mechanical dampers.
WHEELS	Front: spoked rim WM 1/1.6x19" Rear: spoked rim WM 1/1.6x17"
TYRES	Front: 2.50x19" Rear: 3.00x17"
BRAKES	Mechanical expanding type. Front: hand controlled (brake shoe dia. 124 mm, width 24.5 mm); rear: foot controlled with pedal on the L/H side of the vehicle (brake shoe dia. 124 mm, width 24.5 mm).
DIMENSIONS AND WEIGHT	Wheelbase (fully loaded) 1245 mm Max. length 1920 mm Max. width 875 mm Max. height 1100 mm Weight (dry) 72 kg
PERFORMANCES	Max speed: according to Italian road regulations. Consumption: 2.75 l x 100 km (CUNA)
FUEL AND OIL CAPACITIES	Fuel tank: 9.5 l petrol oil mixture «AGIP F.1 2T» oil 3%. Oil sump: 0.500 kg oil «AGIP F.1 Motoroil HD SAE 20W/30».

2.8 MAGNUM

ENGINE	One cylinder - 2 stroke Bore 40 mm Stroke 39 mm Displacement 49 cc Max output 1.2 HP at 5400 rpm Compression ratio 8.2 to 1
FUEL	Petrol oil mixture, oil 3%
IGNITION	Magneto-flywheel/alternator (6V - 18W)
CLUTCH	Multiplate in oil bath, hand controlled with lever on L/H side of handlebar.
GEARBOX	5 speeds foot controlled with pedal on R/H side of the vehicle. Gear ratios: 1st gear (Z = 16/48) = 1 to 3.000 2nd gear (Z = 23/42) = 1 to 1.826 3rd gear (Z = 27/38) = 1 to 1.407 4th gear (Z = 30/35) = 1 to 1.166 5th gear (Z = 33/32) = 1 to 0.969
TRANSMISSIONS	Primary (engine-gear box): by gears Ratio (Z = 21/71) = 1 to 3.38 Secondary (pinion-crown gear): by chain Ratio (Z = 11/43) = 1 to 3.909 Overall ratio (engine-wheel) = 1 to 12.816
FRAME	Tubular structure.
SUSPENSIONS	Front: telescopic fork. Rear: swing arm with mechanical dampers.
WHEELS	Light alloy castings. Front and rear rims 2.10x10".
TYRES	Front and rear: 4.00x10".
BRAKES	Mechanical expanding type. Front: hand controlled (brake shoe dia. 90 mm, width 18 mm); rear: foot controlled with pedal on the L/H side of the vehicle (brake shoe dia. 90 mm, width 18 mm).
DIMENSIONS AND WEIGHT	Wheelbase (fully loaded) 1040 mm Max. length 1530 mm Max. width 720 mm Max. height 980 mm Weight (dry) 55 kg
PERFORMANCES	Max speed: according to Italian road regulations. Consumption: 2.2 l x 100 km (CUNA).
FUEL AND OIL CAPACITIES	Fuel tank: 3 l petrol oil mixture «AGIP F.1 2T» oil 3%. Oil sump: 0.500 kg oil «AGIP F.1 Motoroil HD SAE 20W/30".

2.9 125 TURISMO

ENGINE	One cylinder - 2 stroke Bore 56 mm Stroke 49 mm Displacement 120.62 cc Max output 15.4 HP SAE at 7700 rpm Compression ratio 9.934 to 1
FUEL	Petrol oil mixture, oil 3%
IGNITION	Magneto-flywheel/alternator (6V - 18W)
CLUTCH	Multiplate in oil bath, hand controlled with lever on the L/H side of the handlebar.
GEARBOX	5 speeds, constant mesh gears. Foot operated with pedal on the R/H side of the vehicle. Gear ratios: 1st gear (Z = 16/48) = 1 to 3.000 2nd gear (Z = 23/42) = 1 to 1.826 3rd gear (Z = 27/38) = 1 to 1.407 4th gear (Z = 30/35) = 1 to 1.166 5th gear (Z = 33/32) = 1 to 0.969
TRANSMISSIONS	Primary (engine-gear box): by gears Ratio (Z = 24/68) = 1 to 2.833. Secondary (pinion-crown gear): by chain Ratio (Z = 13/38) = 1 to 2.923 Overall ratio (engine-wheel) = 1 to 8.03.
FRAME	Tubular structure.
SUSPENSIONS	Front: telescopic fork with hydraulic dampers. Rear: swing arm hydraulic dampers with externally adjustable springs.
WHEELS	Front and rear: spoked rims WM 1/1.6x18.
TYRES	Front: 2.50x18" Rear: 2.75x18"
BRAKES	Front: disc brake, fixed caliper with double braking cylinder. Hand controlled with lever on the R/H side of the handlebar. Disc dia. 220 mm, braking cylinder dia. 30 mm, master cylinder dia. 13 mm. Rear: mechanical expanding type. Foot controlled with pedal on the L/H side of the vehicle. Brake shoe dia. 124 mm; width 24.5 mm.
DIMENSIONS AND WEIGHT	Wheelbase (fully loaded) 1230 mm Max. length 1890 mm Max. width 770 mm Max. height 1010 mm Weight (dry) 85 kg
PERFORMANCES	Max speed: 118 km/h about. Consumption: 3.25 l x 100 km (CUNA).
FUEL AND OIL CAPACITIES	Fuel tank: 10.5 l petrol oil mixture «AGIP F.1 2T» oil 3%. Oil sump: 0.500 kg oil «AGIP F.1 Motoroil HD SAE 20W/30».

2.10 125 ENDURO

ENGINE	One cylinder - 2 stroke Bore 56 mm Stroke 49 mm Displacement 120.62 cc Max output 15.4 HP SAE at 7800 rpm Compression ratio 9.93 to 1
FUEL	Petrol oil mixture, oil 3%
IGNITION	Magneto-flywheel/alternator (6V - 25 + 5W)
CLUTCH	Multiplate in oil bath, hand controlled with lever on the L/H side of the handlebar.
GEARBOX	5 speeds, constant mesh gears. Foot controlled with pedal on the R/H side of the vehicle. Gear ratios: 1st gear (Z = 16/48) = 1 to 3.000 2nd gear (Z = 23/42) = 1 to 1.826 3rd gear (Z = 27/38) = 1 to 1.407 4th gear (Z = 30/35) = 1 to 1.166 5th gear (Z = 33/32) = 1 to 0.969
TRANSMISSIONS	Primary (engine-gear box): by gears Ratio (Z = 24/68) = 1 to 2.833 Secondary (pinion-crown gear): by chain Ratio (Z = 13/42) = 1 to 3.230 Overall ratio (engine-wheel) = 1 to 8.866
FRAME	Tubular structure.
SUSPENSIONS	Front: telescopic fork with hydraulic dampers. Rear: swing arm, hydraulic dampers with externally adjustable springs.
WHEELS	Front: spoked rim 1.5x21". Rear: spoked rim 2/1.85x18".
TYRES	Front: 2.50-21". Rear: 3.50-18".
BRAKES	Mechanical expanding type. Front: hand controlled with lever on the R/H side of the handlebar; rear: foot controlled with pedal on the L/H side of the vehicle. Brake shoe dia. 135 mm, width 24.5 mm.
DIMENSIONS AND WEIGHT	Wheelbase (fully loaded) 1300 mm Max. length 2000 mm Max. width 820 mm Max. height 1115 mm Weight (dry) 98 kg
PERFORMANCES	Max speed: 110 km/h about. Consumption: 4.84 l x 100 km (CUNA).
FUEL AND OIL CAPACITIES	Fuel tank: 8.5 l petrol oil mixture «AGIP F.1 2T» oil 3%. Oil sump: 0.500 kg oil «AGIP F.1 Motoroil HD SAE 20W/30".

3.1 MOTORELLA (fig. 1/1)

- 1 Horn
- 2 Headlight
- 3 Steering lock
- 4 Basket
- 5 Front brake control lever
- 6 Throttle control grip
- 7 Lights switch, horn, engine stop button
- 8 Clutch lever
- 9 Rear brake control lever
- 10 Fuel filler cap
- 11 Seat adjusting screw
- 12 Tail light
- 13 Chain adjuster
- 14 Kick starter pedal
- 15 Stand
- 16 Foot rest
- 17 49cc engine with automatic clutch
- 18 Fuel tap
- 19 Starter lever on carburettor
- 20 Spark plug
- 21 Carburettor filter

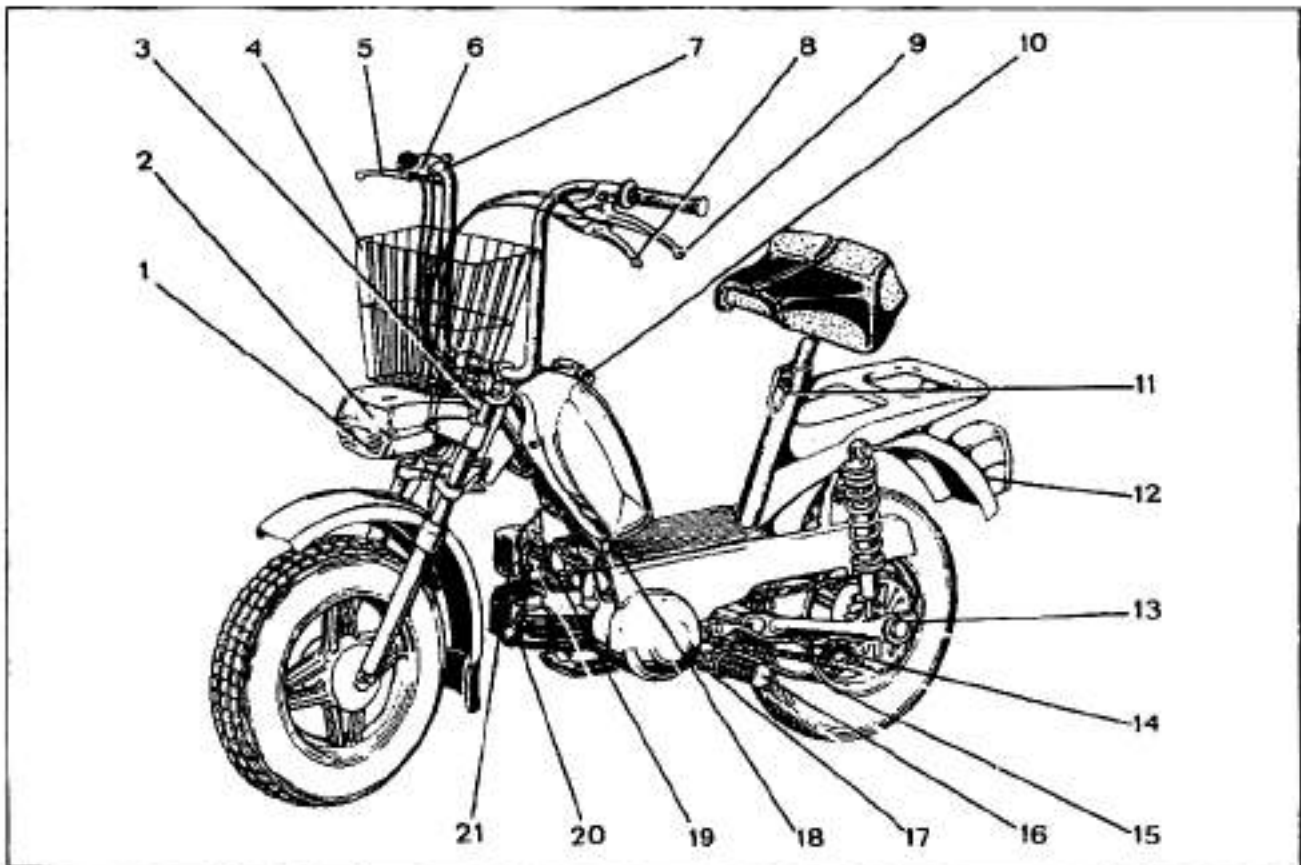

3.2 G2 WITH PEDALS (fig. 2)

- 1 Spark plug
- 2 Starter lever on carburettor
- 3 Starter filter on carburettor
- 4 Horn
- 5 Headlight
- 6 Steering adjuster
- 7 Front brake control lever
- 8 Throttle control grip
- 9 Lights switch, horn, engine stop button
- 10 Clutch lever
- 11 Rear brake control lever
- 12 Seat
- 13 Breathing valve (to be kept constantly pressed when refilling the fuel tank)
- 14 Tool box
- 15 Luggage carrier
- 16 Tail light
- 17 Fuel tap
- 18 Chain adjuster
- 19 Kick starter and foot rest
- 20 Stand

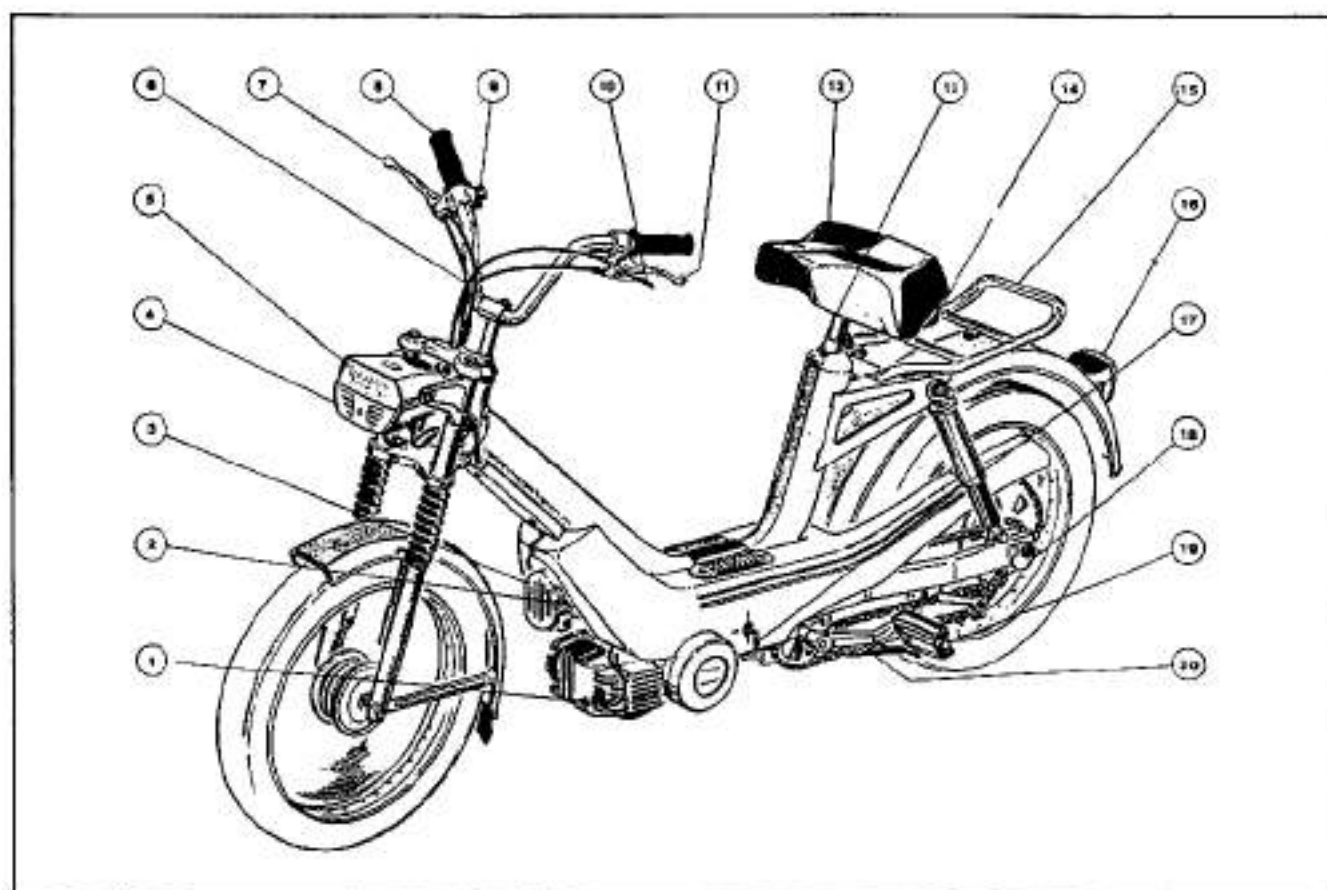

3.3 G2 ELLE - G2 KS (fig. 2/1)

- 1 Spark plug
- 2 Starter lever on carburettor
- 3 Carburettor filter
- 4 Horn
- 5 Headlight
- 6 Steering adjuster
- 7 Front brake control lever
- 8 Throttle control
- 9 Lights switch, horn, engine stop button
- 10 Clutch lever
- 11 Rear brake control lever
- 12 Seat
- 13 Breathing valve (to be kept constantly pressed when refilling the fuel tank)
- 14 Luggage carrier
- 15 Dampers
- 16 Tail light
- 17 Chain
- 18 Chain adjuster
- 19 Kick starter
- 20 Stand

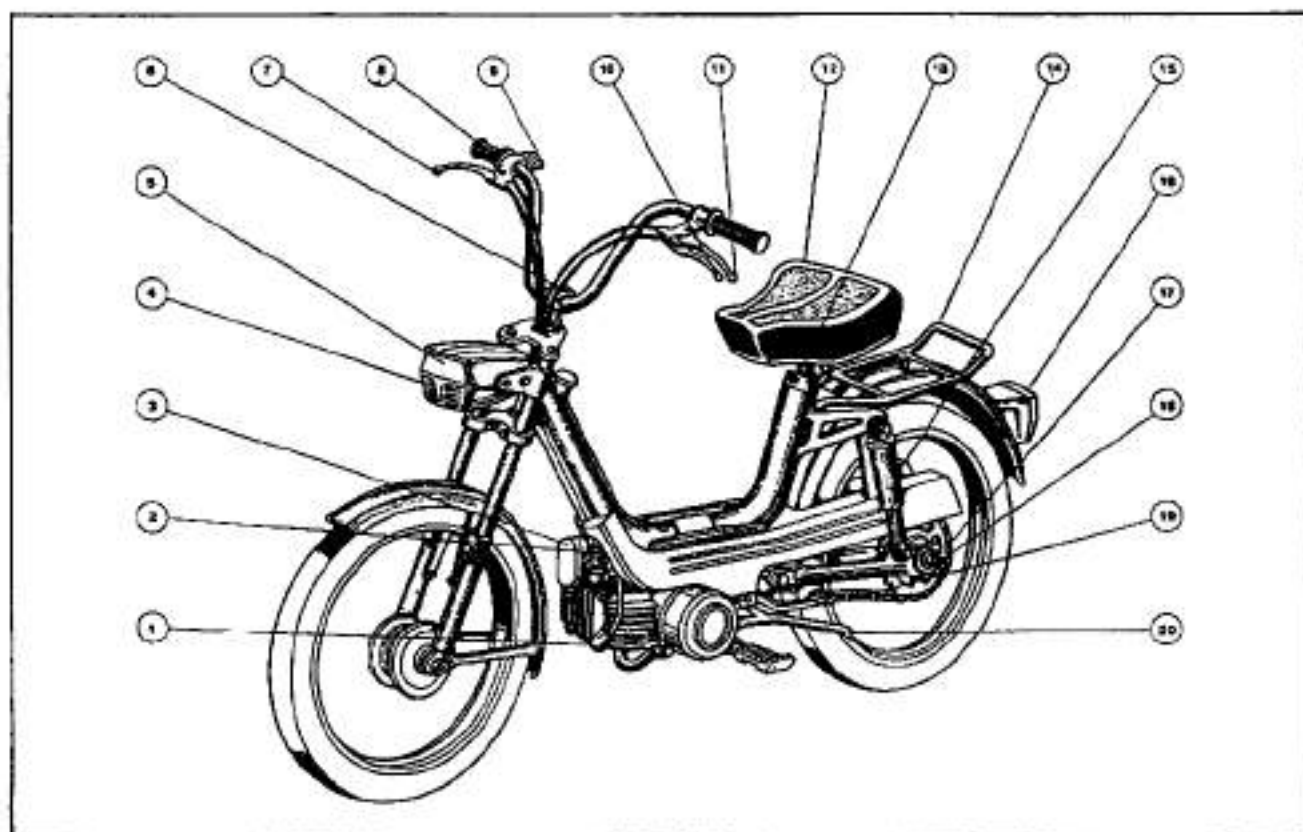

3.4 MAGNUM 3V (fig. 3)

- 1 Spark plug
- 2 Starter lever on carburettor
- 3 Horn
- 4 Headlight
- 5 Steering lock
- 6 Fuel filler cap
- 7 Front brake control lever
- 8 Throttle control
- 9 Lights switch, horn, engine stop button
- 10 Gear box control adjusters
- 11 Clutch and gear box control lever
- 12 Breathing valve (to be kept constantly pressed when refilling the fuel tank)
- 13 Seat
- 14 Seat adjusting clamp
- 15 Tool box
- 16 Luggage carrier
- 17 Dampers
- 18 Tail light
- 19 Kick starter
- 20 Chain adjuster
- 21 Stand

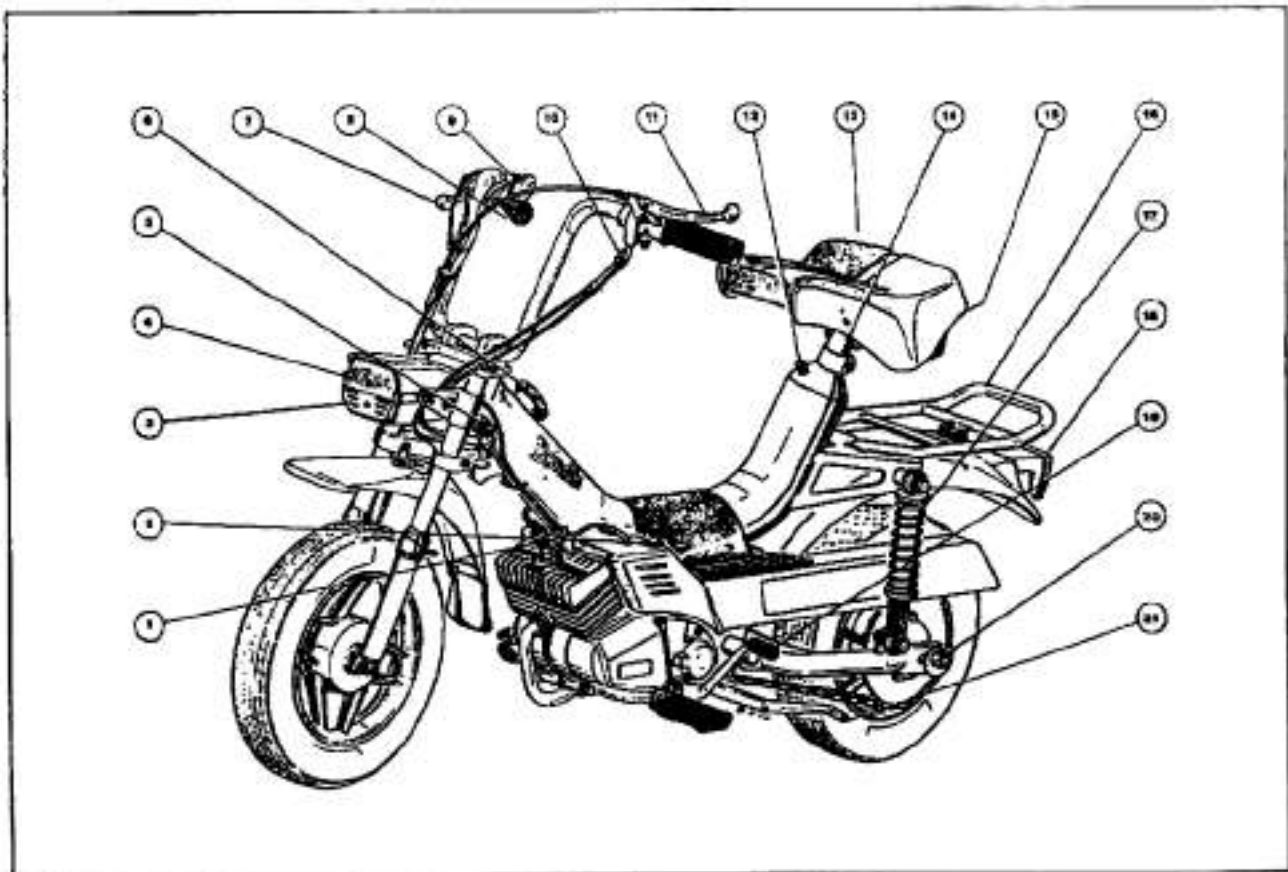

3.5 EXPORT 3V (fig. 4)

- 1 Spark plug
- 2 Fuel tap
- 3 Starter lever on carburettor
- 4 Horn
- 5 Headlight
- 6 Front brake control lever
- 7 Throttle control
- 8 Lights switch, horn, engine stop button
- 9 Steering adjuster
- 10 Fuel filler cap
- 11 Gear box control
- 12 Clutch and gear box lever
- 13 Seat adjusting screw
- 14 Tool box
- 15 Dampers
- 16 Tail light
- 17 Chain
- 18 Chain adjuster
- 19 Kick starter
- 20 Stand

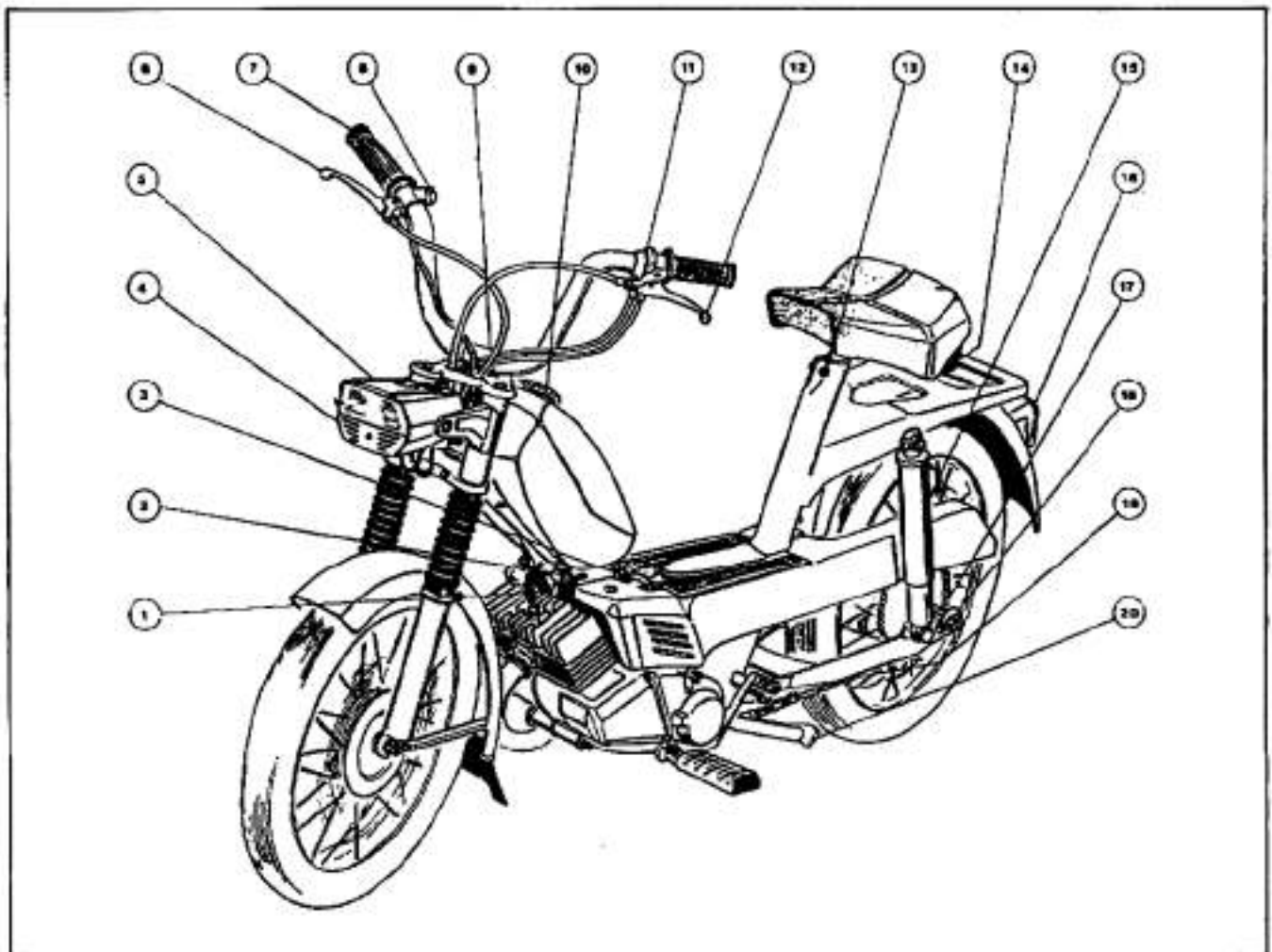

3.6 50 TURISMO (fig. 5)

- 1 Front brake adjuster
- 2 Spark plug
- 3 Horn
- 4 Steering lock
- 5 Clutch cable adjuster
- 6 Front brake control lever
- 7 Front brake cable adjuster
- 8 Throttle control
- 9 Clutch lever
- 10 Lights switch, horn and engine stop button
- 11 Fuel filler cap
- 12 Fuel tap
- 13 Starter lever
- 14 Carburettor filter
- 15 Tool bag
- 16 Kick starter
- 17 Chain tensionner
- 18 Stand
- 19 Brake pedal

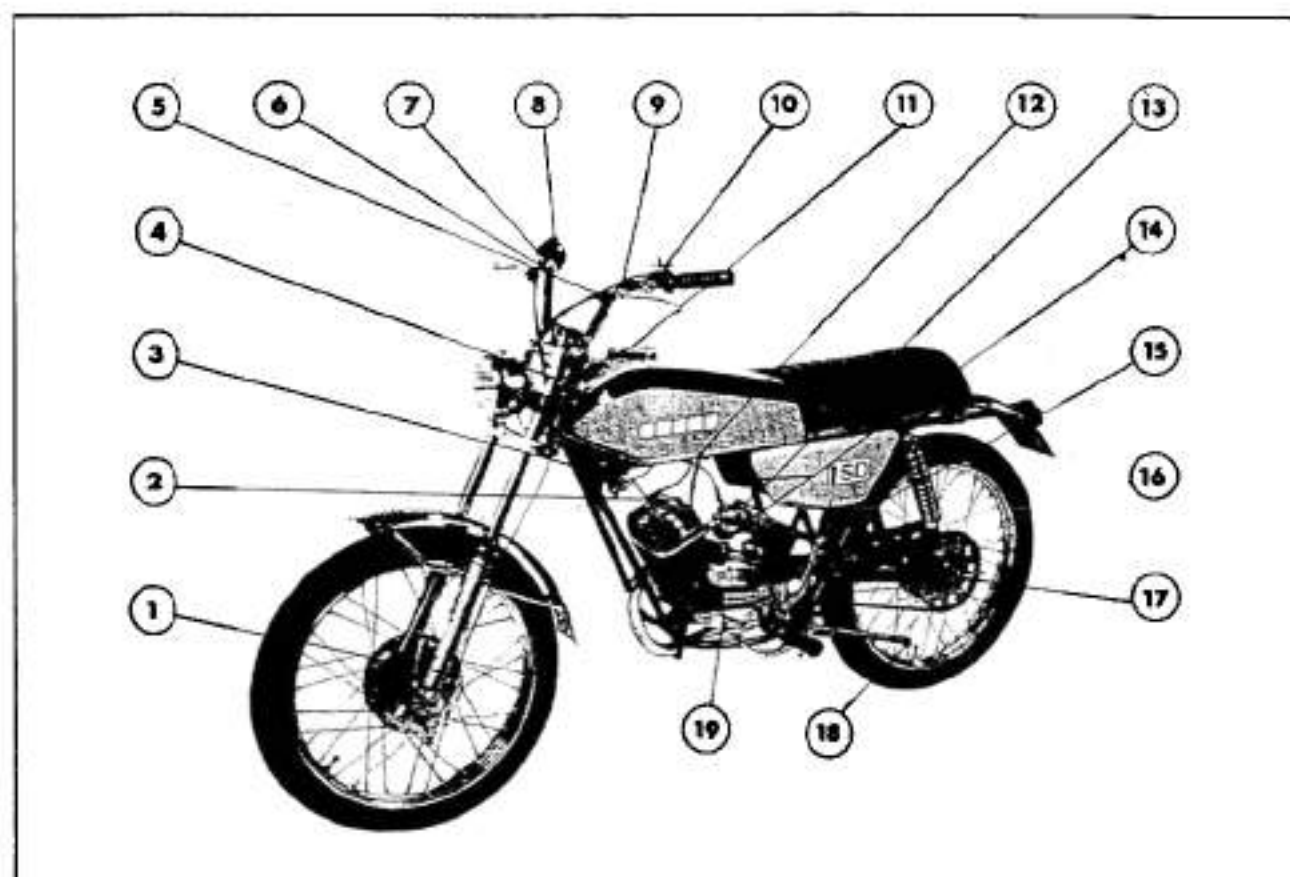

3.7 CROSS (fig. 6)

- 1 Rear brake adjuster
- 2 Chain tensionner
- 3 Rear suspension adjuster
- 4 Silencer tail
- 5 Tail light
- 6 Gear shift pedal
- 7 Air filter
- 8 Starter lever
- 9 Throttle control
- 10 Tool box
- 11 Lights switch, horn and engine stop button
- 12 Clutch lever
- 13 Headlight
- 14 Fuel tap
- 15 Horn

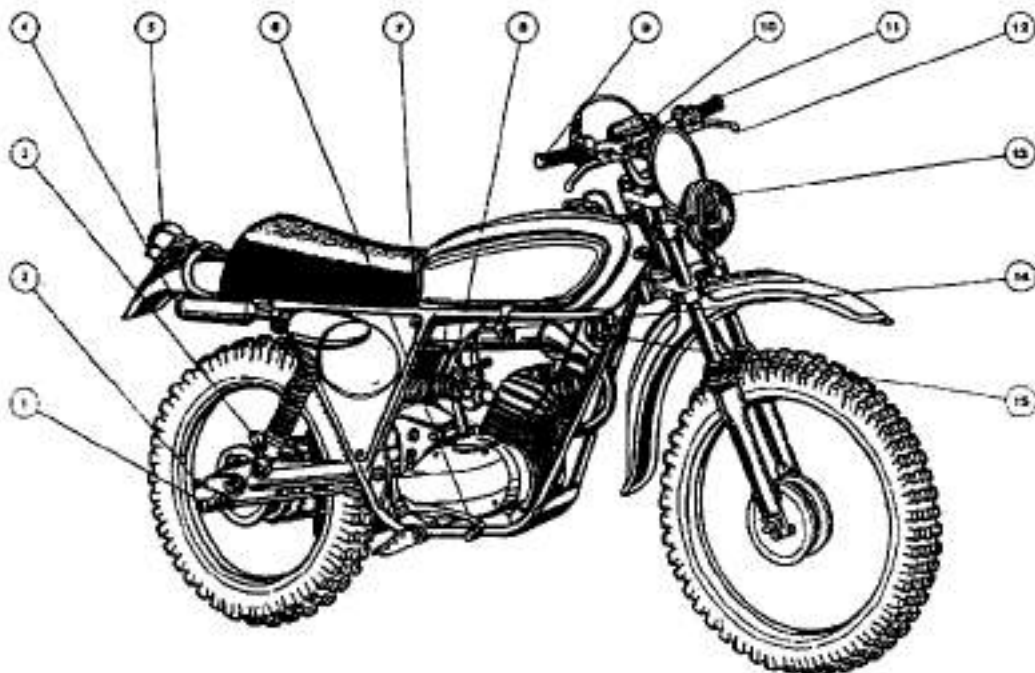

3.8 MAGNUM (fig. 7)

- 1 Rear brake adjuster
- 2 Chain tensionner
- 3 Dampers
- 4 Tail light
- 5 Breathing valve (to be kept constantly pressed when refilling the fuel tank)
- 6 Starter lever on carburettor
- 7 Fuel filler cap
- 8 Front brake control lever
- 9 Throttle control
- 10 Starter lever
- 11 Steering lock
- 12 Horn
- 13 Front brake adjuster
- 14 Spark plug
- 15 Gear shift pedal
- 16 Air filter

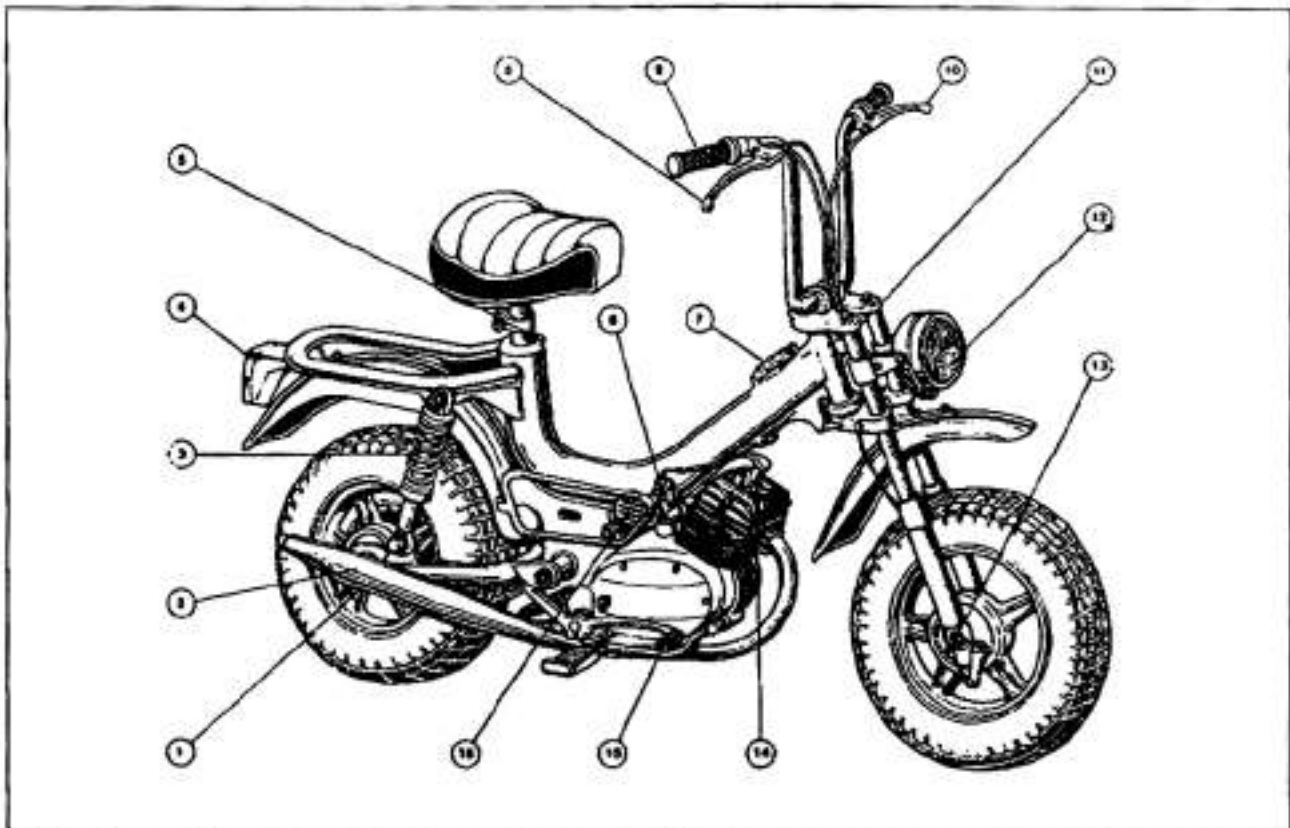

7

3.9 125 TURISMO (fig. 6)

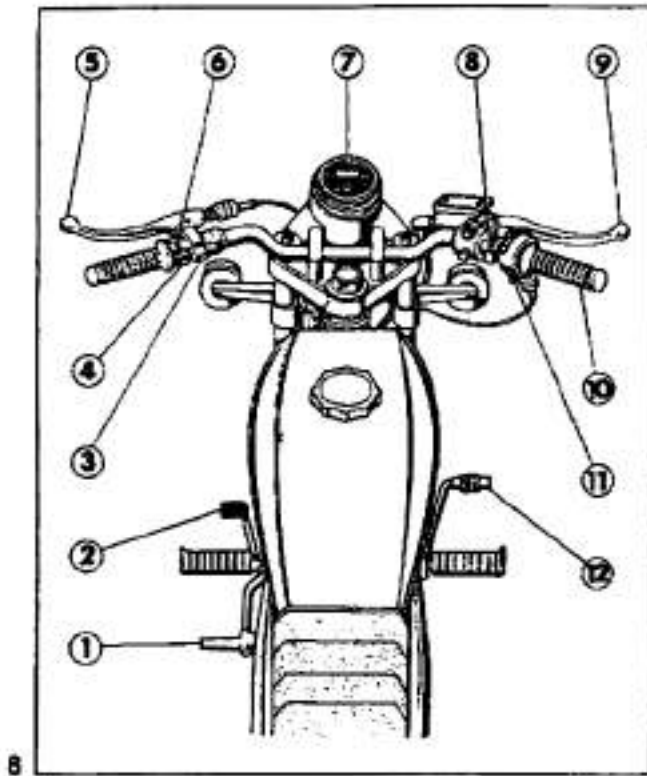

- 1 Kick starter
- 2 Rear brake control pedal
- 3 Lights switch
- 4 Horn button
- 5 Clutch lever
- 6 Turn signals control button
- 7 Speedometer
- 8 Engine stop button
- 9 Front brake control lever
- 10 Throttle control
- 11 Throttle control adjuster
- 12 Gear shift pedal

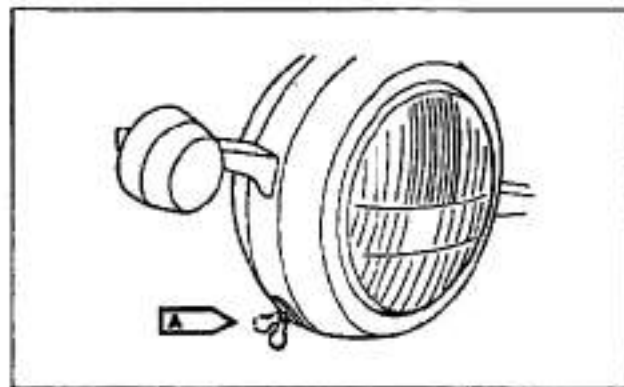

Emergency switch

The electric circuit is equipped with an emergency switch (fitted on the lower R/H side of the headlight) to be used when the STOP light bulb burns. In fact in this condition when operating the brake pedal the engine would stop.

To eliminate this problem it is sufficient to shift the switch lever «A». Do not forget, once the burned bulb replaced, to return the lever to the original position, otherwise the STOP bulb will not light up.

3.10 125 ENDURO (fig. 9)

- 1 Front brake
- 2 Spark plug
- 3 Horn
- 4 H.T. coil
- 5 Switch
- 6 Speedometer
- 7 Front brake control lever
- 8 Front brake adjuster
- 9 Throttle control
- 10 Throttle control cable
- 11 Cable greaser
- 12 Filler plugs
- 13 Switch controlling lights, turn signals and horn
- 14 Clutch cable adjuster
- 15 Clutch lever
- 16 Fuel tap
- 17 Air filter
- 18 Tool box
- 19 Tail light
- 20 Battery
- 21 Starter lever
- 22 Chain tensioner
- 23 Lever adjusting rear suspension
- 24 Kick starter
- 25 Rear fork swing pin
- 26 Stand
- 27 Clutch adjuster
- 28 Brake pedal
- 29 Gear shift pedal
- 30 Fork drain plug
- 31 Front brake cable adjuster

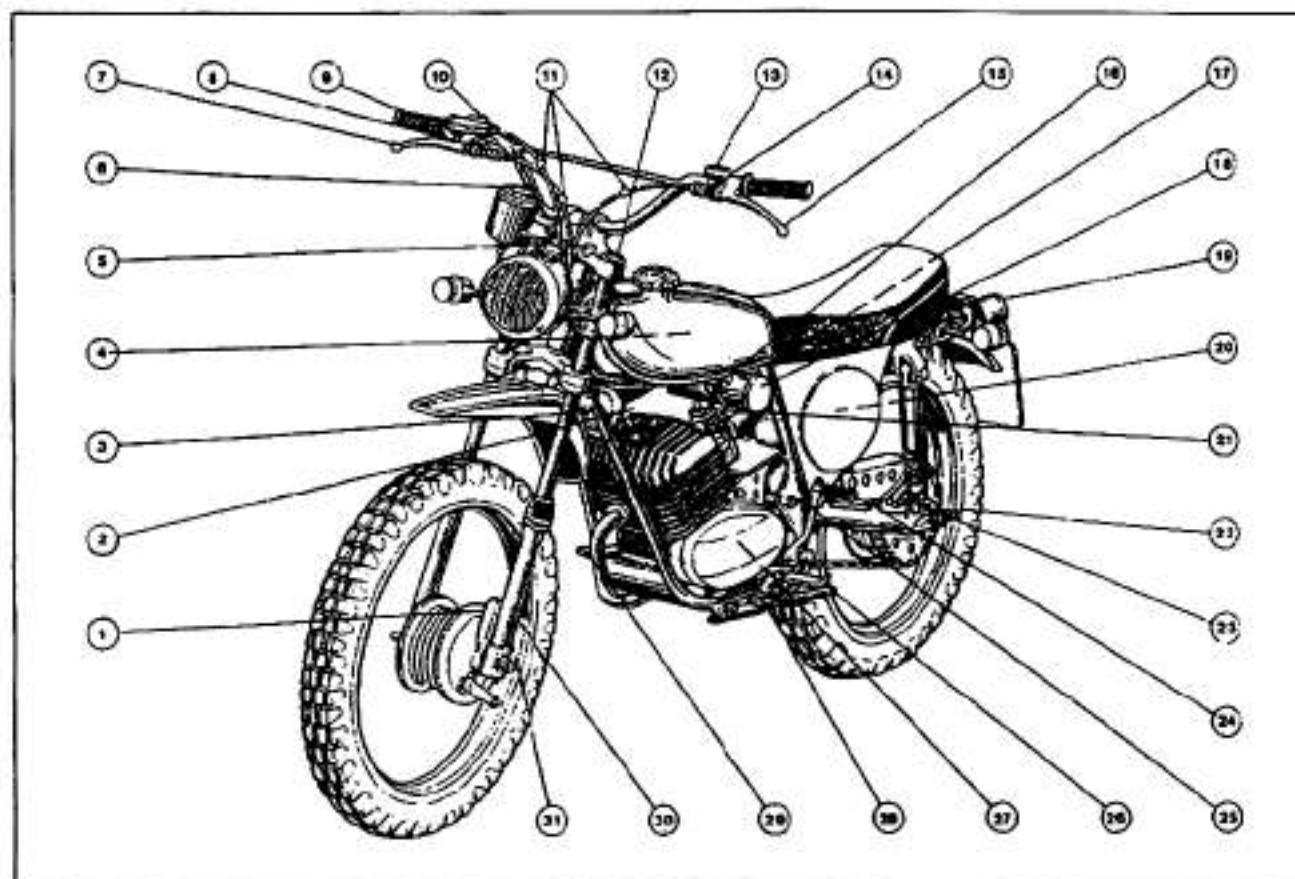

9

Fuel

4% oil petrol mixture for: G2 with pedals - G2 Elle - G2 KS - Motocella 78.

3% oil petrol mixture for: Magnum - 50 Turismo - 50 Cross - Magnum 3V - Export 3V - 125 Turismo - 125 Enduro.

Petrol: Agip F.1 2T.

Tyres

Periodically check tyres pressure.

Front: 1.5 kg/sqcm

Rear: 1.75 kg/sqcm

for models G2 with pedals - G2 Elle - G2 KS - Motocella - Magnum - 50 Turismo - 50 Cross - Magnum 3V - Export 3V.

Front: 1.8 kg/sqcm

Rear: 2 kg/sqcm

for models 125 Turismo - 125 Enduro.

Lubrication of the gear box

After the first 1500 km and at 5000 km intervals change the oil (with a warm engine). Every 1000 km check the oil level, if necessary restore the correct level by adding oil of the same quality and density. Oil «Agip F.1 Motoroil HD SAE 20W/30».

Spark plug

Every 1000 km check the spark plug points gap: 0.5 mm (.019") and clean it with petrol and a wire brush.

Every 10000 km replace the spark plug even if it appears to be still in good condition.

Air filter

Every 2000 km clean the air filter with petrol. For the model Cross clean the air filter in paper with compressed air every 1000 km and replace it every 5000 km.

Fuel filters

Every 2000 km clean the fuel tap filter and carburettor filter.

Chain

Whenever necessary remove the drive chain and wash it in a petrol bath, carefully dry and smear it with «Agip F.1 Grease 30» or «Agip Rocol Chain & Drive Spray».

Magneto-Flywheel

Every 5000 km check the condition and the points gap of contact breaker (0.4 mm). Lightly moisten the cam.

Cylinder head, piston, exhaust pipe

Every 5000 km clean all these parts.

Fuel tank

Every 5000 km clean it with petrol and with the aid of an iron chain.

Carburettor

Every 5000 km it is necessary to remove the carburettor to carefully check and clean it.

Steering

Every 1000 km remove steering caps and balls and clean them. If damaged replace. Fill the caps with «Agip F.1 Grease 30» and dip the balls.

Wheel hub

Every 10000 km remove the wheel hubs and carefully clean the ball bearing. If damaged replace them. Lubricate with «Agip F.1 Grease 30».

5.1 GEARSHIFT PEDAL (fig. 10)

The gearshift pedal is located at the R/H side of the engine. It is foot operated and has to be decisively actuated till the gear is engaged. Once the gear is engaged the pedal will return automatically to its original position. Starting from the neutral (between low and second gear) lifting the pedal it engages the low gear; pressing it it returns to neutral. Press it with decision to engage the second gear and in the same way for the third, fourth and fifth.

To change down lift the pedal going progressively through the gears.

ATTENTION: The gear pedal has to be operated always with the clutch disengaged and when the throttle control is at the minimum position.

5.2 EASY STARTER LEVER FOR 125 TURISMO AND 125 ENDURO (fig. 11)

The starter lever is located on the carburettor. For cold starting move the lever to position «A». When the engine is warm return the lever to position «B».

5.3 ENGINE STOP BUTTON 125 TURISMO (fig. 12)

The engine stop button is located on the R/H side of the handlebar and it is used to stop the engine.

5.4 STEERING LOCK (fig. 13)

It is located on the L/H side of the steering down tube and is actuated by the key.

To lock or unlock the steering, proceed as follows:

- turn the steering fully to the right;
- insert the key in the lock set, turn it backwards (towards the rear wheel) and withdraw it.

To unlock the steering reverse the operation.

5.5 FUEL TAP (fig. 14)

It is located under the fuel tank and it has three positions:

- Closed - see letter «C» stamped on the tap;
- Open - the lever in the vertical position;
- Reserve - see letter «R» stamped on the tap.

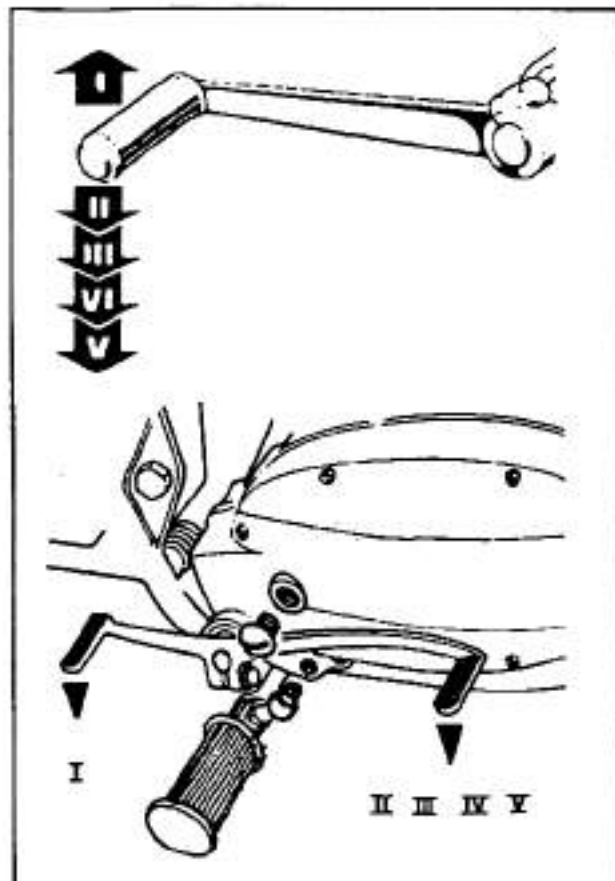

10

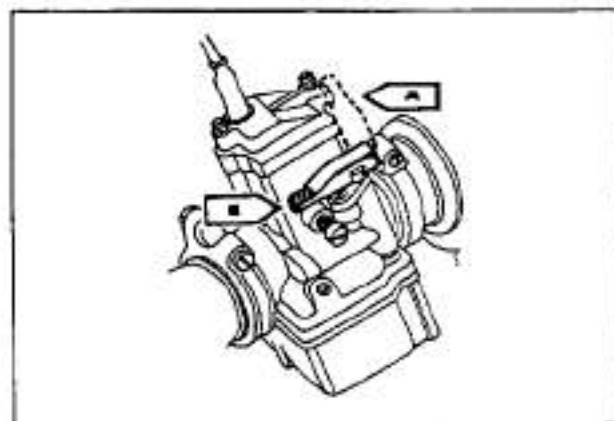

11

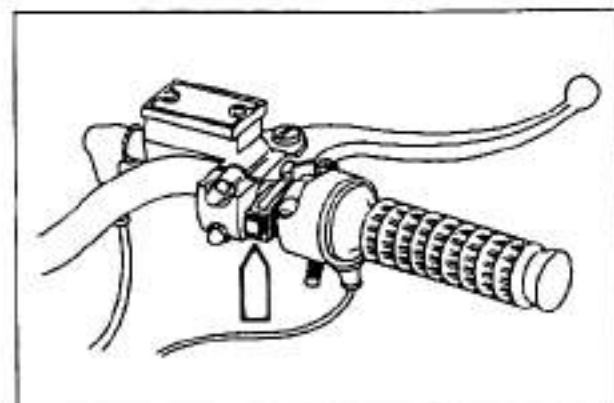

12

13

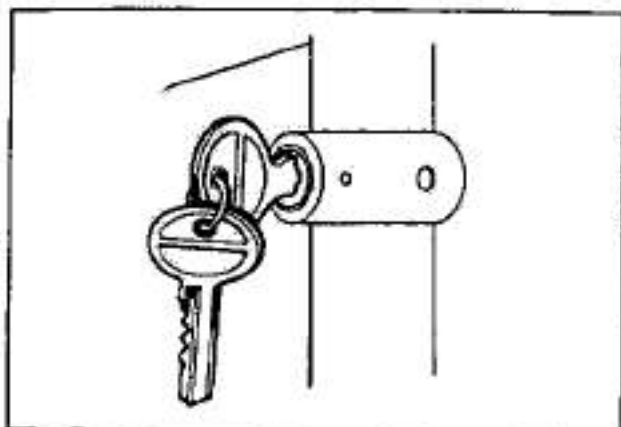

5.6 LIGHTS SWITCH - HORN - ENGINE STOP BUTTON FOR: MOTORELLA - G2 WITH PEDALS G2 KS - EXPORT 3V - MAGNUM 3V - MAGNUM 50 TURISMO - CROSS (fig. 15 and fig. 16)

- A - Horn button
- B - Engine stop button
- C - Lights off
- D - Town light on
- E - High light on.

5.7 LIGHTS SWITCH, HORN, TURN SIGNALS SWITCH FOR: 125 ENDURO (fig. 17)

- A — Lights switch. With ignition key turned clockwise:
- position «1»: low beam
 - position «2»: high beam.
- For the parking light turn the key anticlockwise.
- B — Turn signal switch:
- position «3»: left indicators
 - position «4»: right indicators.
- C — horn button.

14

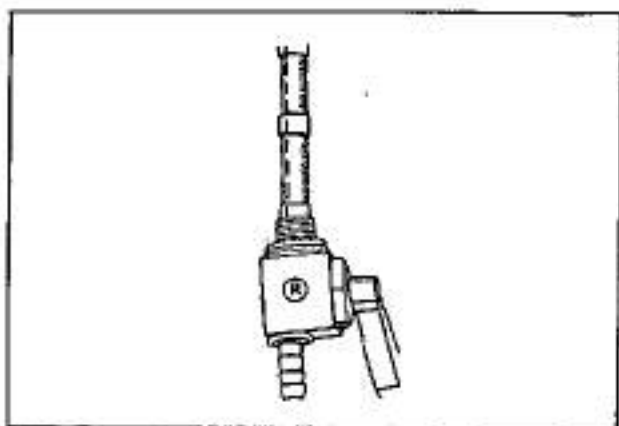

5.8 TURN SIGNALS SWITCH FOR: 125 TURISMO (fig. 18)

It is situated on the L/H side of the handlebar. To operate the indicators move switch «C» to the right or to the left; to turn them off move the switch to position «OFF».

5.9 HORN FOR: 125 TURISMO (fig. 18)

It is situated on the L/H side of the handlebar. To operate it it is necessary to press button «A» (HORN).

5.10 LIGHTS SWITCH FOR: 125 TURISMO (fig. 18)

The lights are selected by switch «D» (LIGHTS) situated on the L/H side of the handlebar and it has three positions.

Position «OFF» (all off), position «L» (low beam), position «H» (high beam).

N.B. - To move switch «D» from position «H» to position «OFF» it is necessary to push towards the left the red button located under the switch same.

15

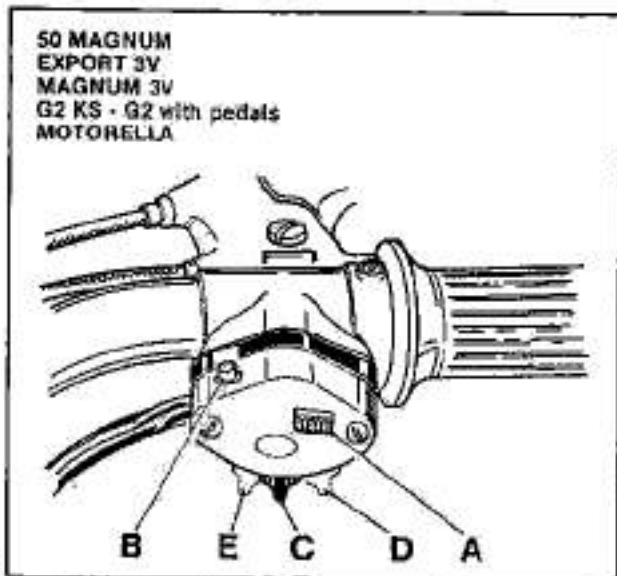

50 TURISMO

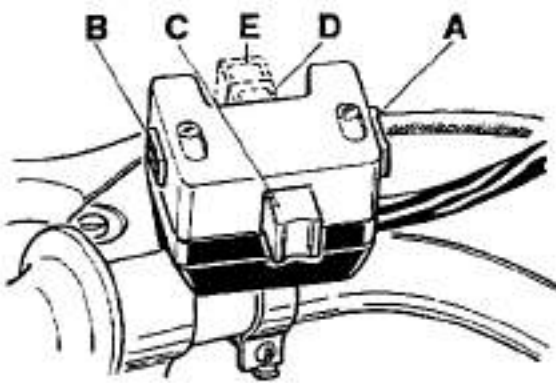

CROSS

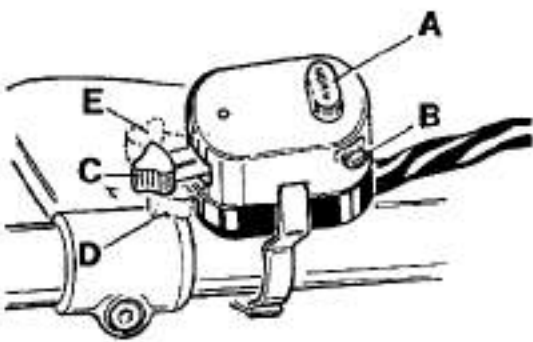

16

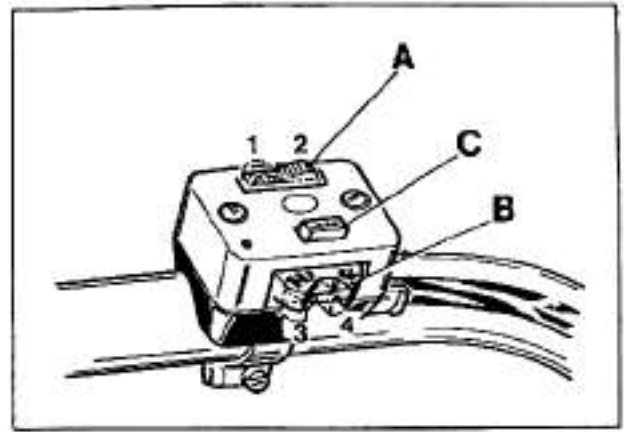

17

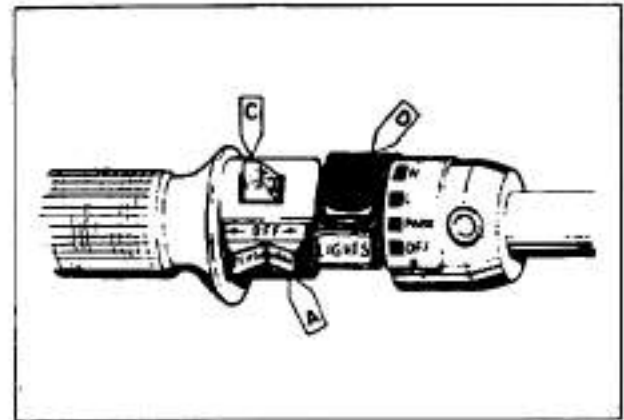

18

6 ADJUSTMENTS

6.1 MOTORELLA - G2 KS - G2 WITH PEDALS EXPORT 3V - MAGNUM 3V

Adjusting starting lever play (fig. 19)

The play of the lever at the handlebar must be of 3.5 to 4 mm.

Adjusting movement of the front and rear brake lever (fig. 19-20)

The idle movement of the front and rear brake lever must be within 20 to 25 mm. To adjust this movement loosen counter nut «B» and operate on adjuster screw «A». At the end of the operation lock counter nut «B».

Adjusting the chain tension (fig. 21)

To adjust the chain tension loosen first the nuts «A» on the rear wheel spindle, then screw in or out the nuts on the chain tensioners «B» to obtain a shake play in the middle of the chain — bike not on stand — of 25-30 mm. Then true the wheel.

Adjusting the steering (fig. 22)

For safe riding the steering has to be adjusted so that the handlebar can move freely without any play.

To adjust the steering loosen head bolt «B». Screw adjusting nut «A» by means of the special tool to obtain the correct play. After adjusting re-tighten nut «B».

Adjusting the wheel-spokes

Ensure that all spokes are properly tensioned and that the wheel rim is quite true. Proceed as follows: Turn the wheel and using a locator, check if the wheel is offset. If necessary tighten or loosen the right or left spokes till the wheel turns without any wobbling. This check should be done after the first 1500 km and then periodically.

Tires

Tires are included in the components which must be very carefully checked as the vehicle stability riding comfort and even the rider's safety are dependant on them. Therefore it is not advisable to use tires having less than 1.5 mm thickness tread.

An incorrect tire pressure may also affect the vehicle stability and cause rapid deterioration of the tire. The recommended pressures are:
front wheel 1.5 kg/sqcm
rear wheel 1.75 kg/sqcm.

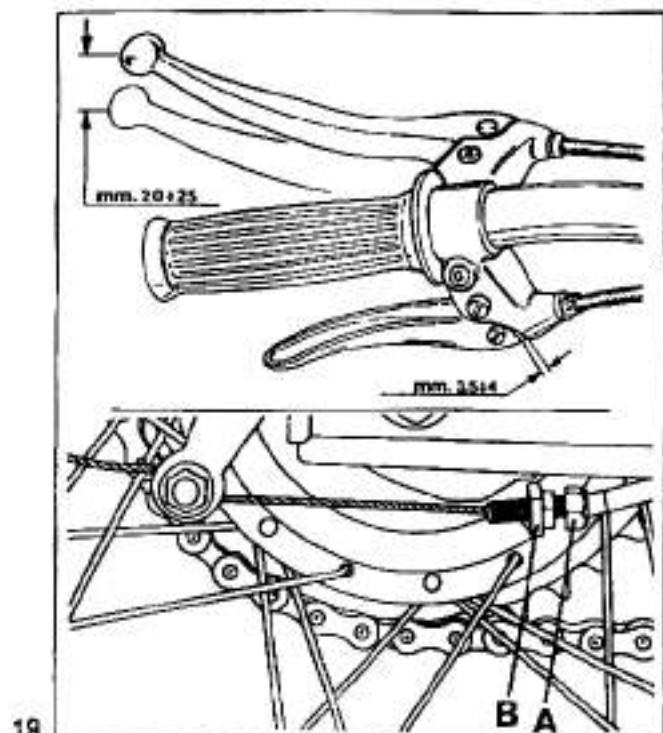

19

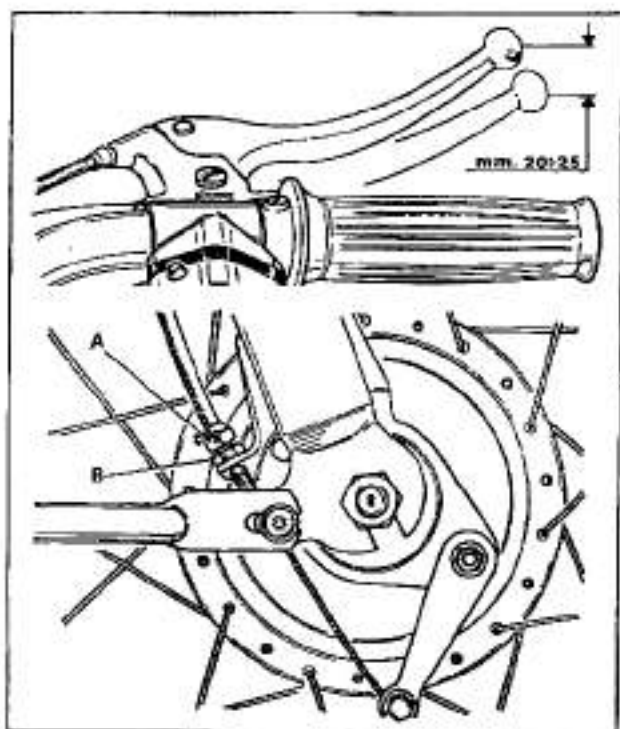

20

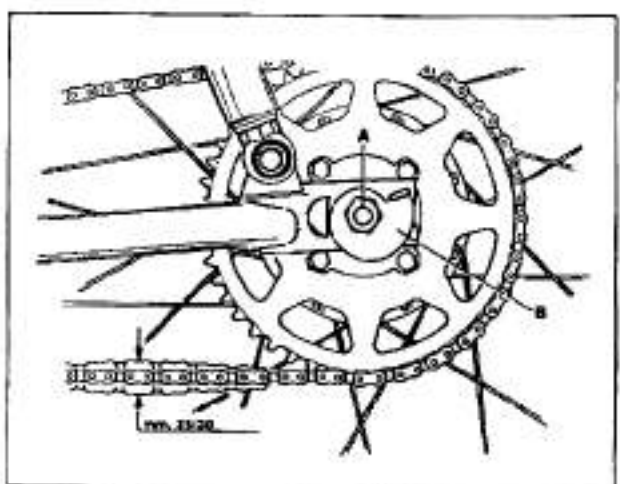

21

6.2 50 TURISMO - CROSS - MAGNUM

Adjusting movement of the front brake lever (fig. 23)

The idle movement of the front brake control lever must be within 20-25 mm. To adjust this movement loosen counternut «B» and operate on adjuster screw «A». At the end of the operation re-tighten counternut «B». For models 50 Turismo and Cross a proper adjuster «C» is provided on the control lever.

Adjusting the movement of the rear brake control pedal (fig. 24)

To adjust the travel of the pedal which has to be within 20 to 25 mm it is necessary to operate on adjusting nut «E». For model Magnum act on adjuster located on the brake shoe plate.

Adjusting the chain tension (fig. 25)

To adjust the chain tension operate as follows:

- loosen nuts «E» on the rear wheel spindle;
- screw in or out the nuts the chain tensioner nuts «F» (for model Magnum, rotate equally the two eccentric chain tensioners) to obtain a snake play in the middle of the chain, bike not on stand, of 25 to 30 mm.
- at the end of the adjustment check that the wheels are on the same line.

Adjusting the clutch lever play (fig. 26)

If the clutch lever play at the handlebar is more or less than 3 to 4 mm operate on thumb screw «A» alter slackening counternut «B» to obtain the correct play. If this adjustment is not sufficient it will be necessary to remove the L/H side cover and operate on the adjuster fitted on the lever.

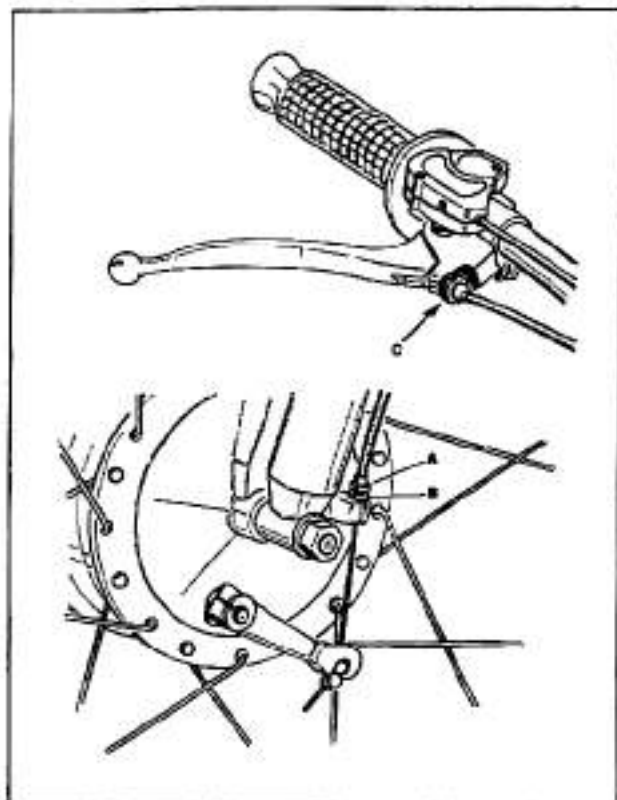

23

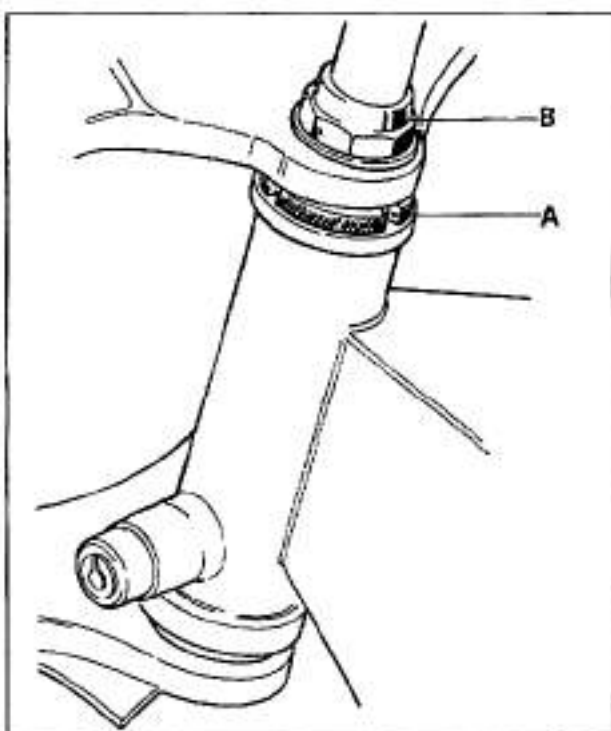

22

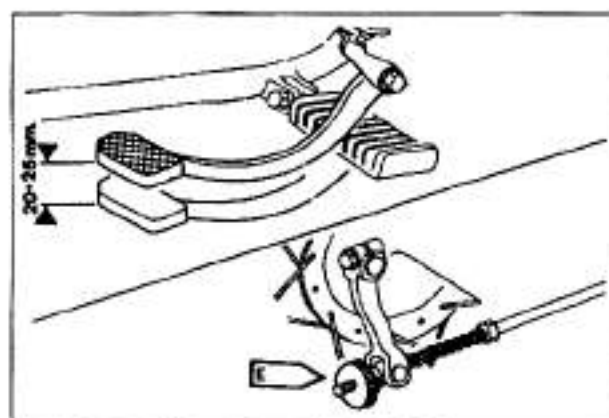

24

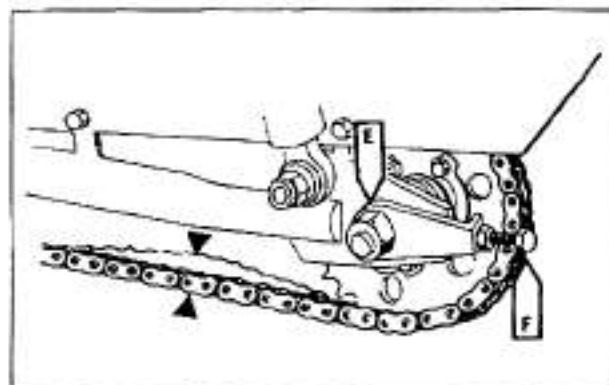

25

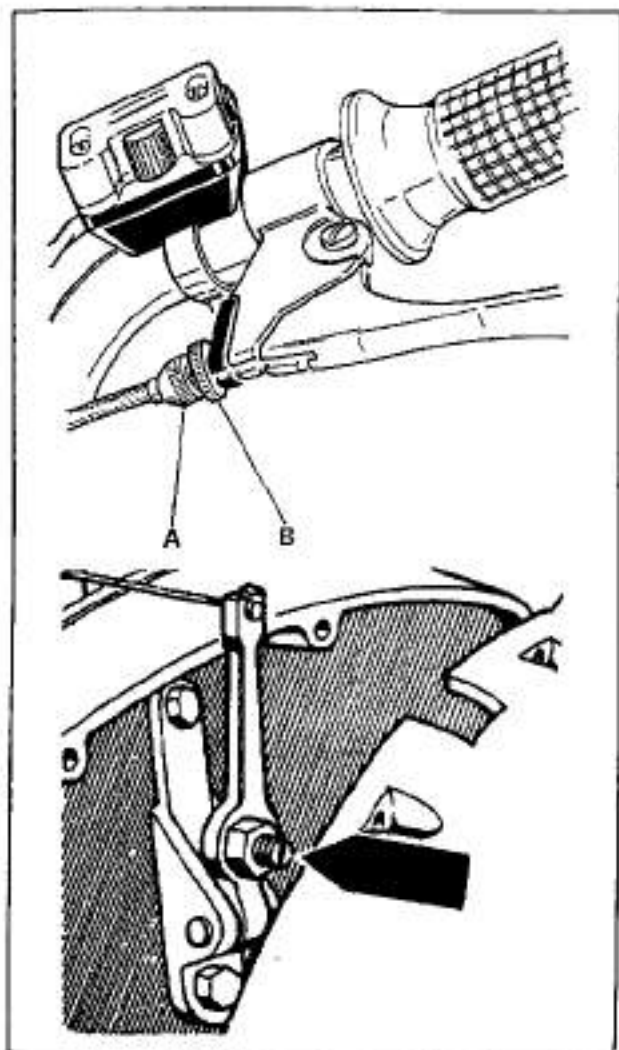

Adjusting the steering (fig. 27)

For safe riding the steering has to be adjusted so that the handlebar can move freely without any play.

To adjust the steering operate as follows:

- loosen steering bolt «C» and by means of the special tool screw adjusting nut «A» in or out until the correct play is obtained;
- after adjusting re-tighten bolt «C».

Adjusting the wheel-spokes

(not valid for model Magnum)

Ensure that all spokes are properly tensioned and that the wheel rim is quite true.

For this checking operate as follows:

- turn the wheel and using a locator check if the wheel is offset; if necessary tighten or loosen the right or left spokes till the wheel turns without any wobbling.
- this check should be done after the first 1500 km and then periodically.

Tires

Tires are included in the components which must be very carefully checked as the vehicle stability riding comfort and even the rider's safety are dependant on them.

Therefore it is not advisable to use tires having less than 1.5 mm thickness tread.

An incorrect tire pressure may also affect the vehicle stability and cause rapid deterioration of the tire. The recommended tire pressures are:

- front wheel 1.5 kg/sqcm
- rear wheel 1.75 kg/sqcm.

6.3 125 TURISMO · 125 ENDURO

Adjusting the clutch lever play (fig. 28)

If the clutch lever play at the handlebar is more or less than 3 to 4 mm operate on thumb screw «A», after slackening counternut «B» to obtain the correct play. If this adjustment is not sufficient it will be necessary to remove the L/H side cover and to operate on the adjuster «C» fitted on the lever.

Adjusting the movement of the front brake lever for 125 Turismo (fig. 29)

For this adjustment slacken counternut «B», screw in or out screw «A» paying attention that with control lever «D» in resting position, piston «C» will not clog up hole «E». At the end of the operation re-tighten counternut «B».

Adjusting the movement of the rear brake control pedal (fig. 30)

If the control lever has too much travel before the shoe linings come in touch with the brake drum screw the knob «E» on the control link, paying attention to leave a free play of 20 to 25 mm measured at the end of the control lever «F» before the linings touch the drum.

26

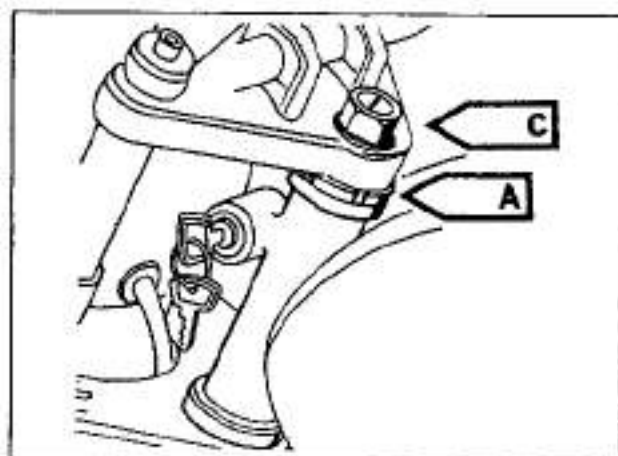

27

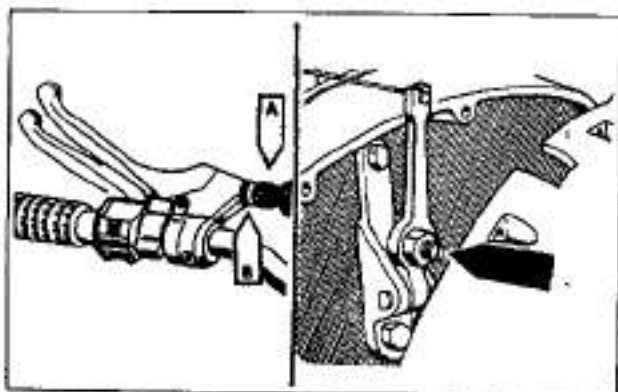

28

Adjusting the movement of the front brake control lever for 125 Enduro (fig. 31)

The idle movement of the front brake control lever must be within 20 to 25 mm. To adjust this movement operate as follows:

- loosen thumb screw «A», screw in or out adjuster screw «B» to obtain the correct movement. If this is not sufficient slacken conternut «D» and operate on screw «C».

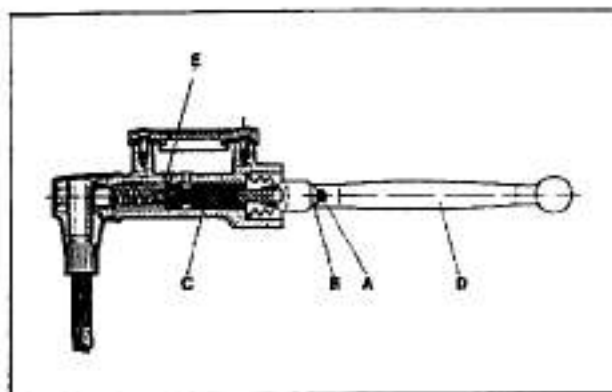

29

Adjusting the rear suspension (fig. 32)

The rear suspensions springs can be adjusted to three different positions starting from position n. 3 (max load).

If the damper action is not correct replace the suspensions. Pay attention that the springs of the two suspensions have to be adjusted to the same position.

Adjusting the throttle control (fig. 33)

The throttle control is located on the R/H side of the handlebar. By turning it towards the rider it opens the throttle valve in the carburettor, releasing it, it returns automatically.

Operate on adjuster screw «G» to adjust the travel of the throttle control grip.

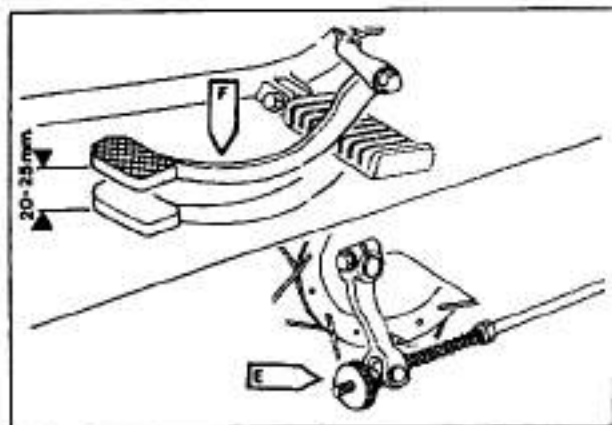

30

Adjusting the chain tension (fig. 34)

With the motorcycle off the stand, the chain must have an up and down free play of 25 to 30 mm measured in the middle in order to avoid excessive tightening during the rear fork swinging.

To adjust proceed as follows:

- slacken nut «E» (wheel spindle) and turn the chain adjuster bolts «F» in order to centralize the wheel in the rear fork.

After this adjustment remember to adjust the free play of the rear brake control lever (see proper chapter).

Adjusting the steering (fig. 35)

For safe riding the steering has to be adjusted so that the handlebar can move freely without any play.

To adjust the steering operate as follows:

- loosen head bolt «C» and by means of the special tool screw in or off the adjuster ring «A» to obtain the correct play.
- after the adjustment lock nut «B».

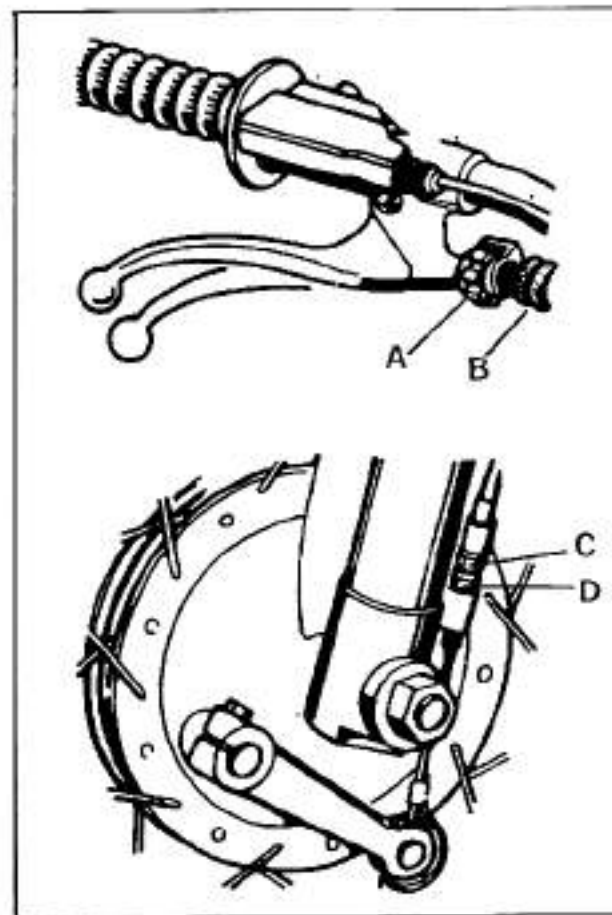

31

Adjusting the wheel spokes

Ensure that all spokes are properly tensioned and that the wheel rim is quite true. Proceed as follows:

- turn the wheel and using a locator, check if the wheel is offset; if necessary tighten or loosen the right or left spokes till the wheel turns without any wobbling.
- this check should be done after the first 1500 km and afterwards periodically.

32

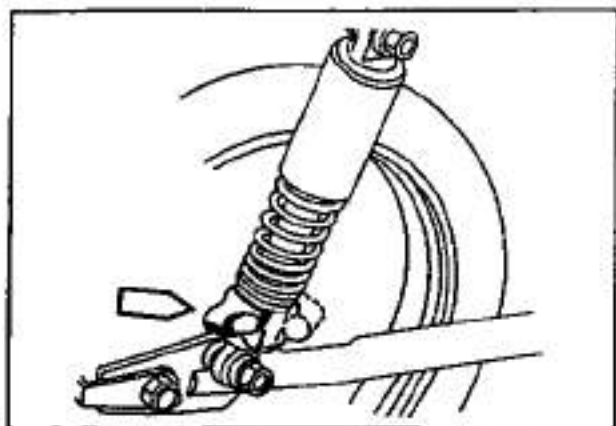

Balancing the wheels

To improve stability and decrease vibrations at high speed the wheels have to be kept balanced.

To balance the wheels proceed as follows:

- ensure that all spokes are tightened and the wheel is true;
- lightly spin the wheel several times and see if it always stops in various positions, thus indicating a correct balance;
- if one point of the wheel always stops at the bottom, put a balance weight on the spoke opposite this point;
- repeat this operation until the wheel is correctly balanced, then fix the balance weights to the spokes by means of pliers.

33

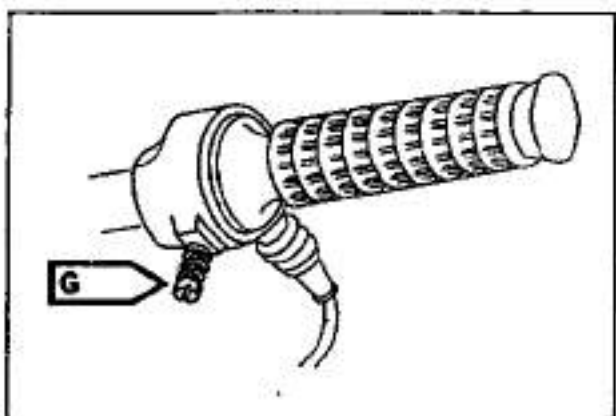

Tires

Tires are included in the components which must be very carefully checked as vehicle stability, riding comfort and even rider safety are dependant on them.

Therefore it is inadvisable to use tires having less than 1.5 mm thickness tread.

An incorrect tire pressure may also affect the vehicle stability and cause rapid wear of the tire.

The recommended pressures are: for the front wheel 1.8 kg/sqcm; for the rear wheel 2 kg/sqcm; with pillion increase the pressure by 0.2 kg/sqcm.

If using the motorcycle at constant speed it is recommended to increase the pressure by 0.15 kg/sqcm.

34

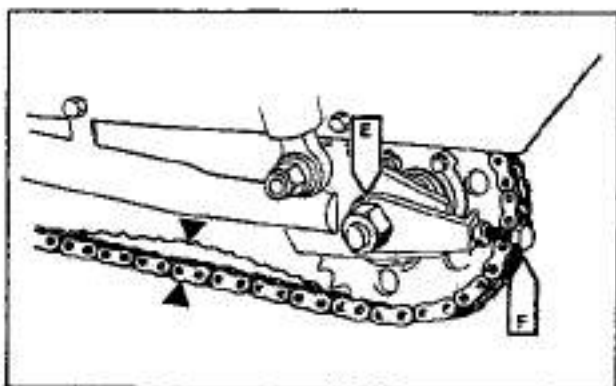

Directions for inspection and overhauling the front brake for 125 Turismo

For proper operation of brake these directions are to be followed:

- periodically check the fluid level in the master cylinder (fluid reservoir, after undoing the two screws «C» (fig. 36) and removing cover «B»; the level must never be lower than 5 mm from the top part of the reservoir; if necessary top up the fluid reservoir (only use «Agip F.1 Brake Fluid SAE J1703B» taken from an original container which must only be opened when using the fluid itself).
- every 20000 km or max every two years completely renew the brake fluid.

In case of washing use only fresh fluid, no alcohol is to be used for washing and no compressed air for drying; for metal parts the use of trichloroethylene is recommended.

Every 5000 km check pad wear.

Thickness should be:

new pad 5.5 mm

wear limit 3 mm.

After pads replacing operation it is not necessary to bleed the air from the circuit. All that needs to be done is to actuate the handlebar control lever several times until the plungers return to their normal position.

IMPORTANT: after the pads replacement it is advisable not to brake vigorously for the first 100 km in order to allow the pads to settle down completely. Carefully check the conditions of the fluid ducts; if any may be damaged replace them immediately. The brake disc should be perfectly clean, without oil, grease or other impurity, also free from deep scoring.

35

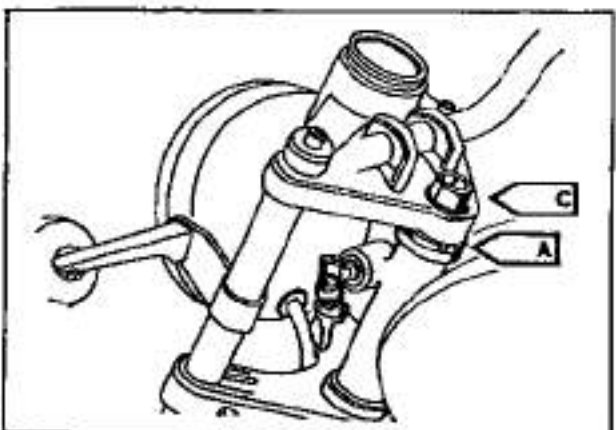

Air bleeding from the braking circuit (fig. 36)

This operation is required when the movement of the control lever on the handlebar is long and elastic because of the presence of air inside the braking circuit.

For this operation proceed as follows:

- a. fill up reservoir (ensuring that during the bleeding operation the fluid does not drop below the minimum level).
- b. fit a transparent pipe on drain plug «A» with the other pipe end plunged into a transparent container partially filled up with fluid of the same type.
- c. loosen drain plug «A».
- d. operate the brake control lever on the handlebar and lock drain plug «A» before the lever is fully pulled.
- e. repeat this operation several times until the pipe end plunged into the container emits airless fluid.
- f. keep the lever fully pulled and lock drain plug «A». Remove the pipe and refit rubber cap on drain plug.

If the air bleeding has been carried out correctly, a direct and efficient working of the fluid will be perceived immediately after the initial idle movement of the control lever. If not repeat the above operation.

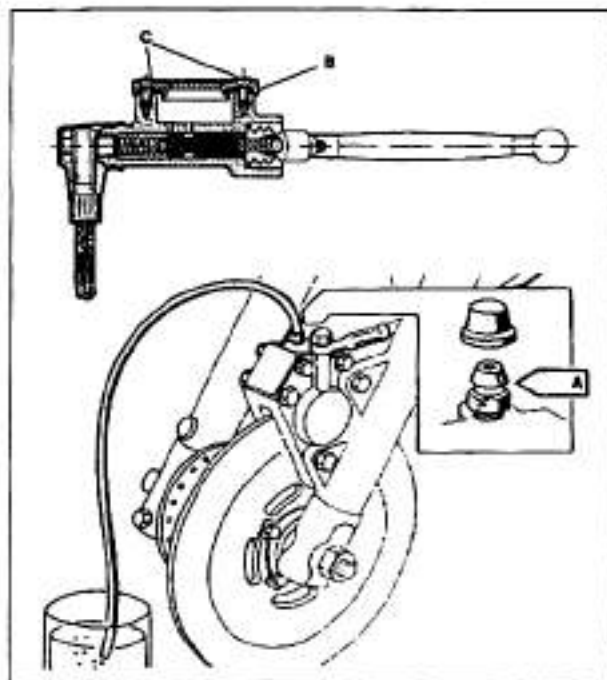

POS. N°	PART. N.	DESCRIPTION	Motorola	02 ref. pieces	02	Magnam 20	Erson 20	50 Tuilano	Magnam	Cross	125 Tuilano	125 Erson
1	48 91 26 70	Puller, chain pinion	X	X				X	X	X	X	X
2	48 90 27 70	Tool fitting flywheel fitting chain pinion	X	X	X	X	X					X
3	35 90 27 00	Tool fitting flywheel fitting chain pinion	X					X	X	X	X	X
4	69 90 81 00	Tool, chain pinion holdfast									X	
5	43 90 63 00	Puller, magneto flywheel	X	X	X	X	X	X	X	X	X	X
6	35 90 63 01	Puller, engine pinion				X	X	X	X	X	X	X
7	35 90 15 00	Tool, engine pinion holdfast						X	X	X		
7	35 91 15 70	Tool, engine pinion holdfast									X	X
8	35 90 65 00	Tool, fitting clutch						X	X	X	X	X
9	35 90 61 00	Tool, clutch discs holdfast						X	X	X	X	X
10	48 90 61 70	Tool gear transmission holdfast Rimoldi clutch holdfast		X								
11	48 91 27 70	Puller, Adler clutch plate	X	X	X							
12	69 90 33 00	Puller, clutch housing	X	X	X							
13	69 90 61 00	Puller, Rimoldi clutch plate	X	X	X							
14	69 90 78 00	Tool, fitting piston pin	X	X	X	X	X					
14	39 90 78 51	Tool, fitting piston pin									X	X
14	39 90 78 52	Tool, fitting piston pin						X	X	X		
15	69 90 81 03	Tool, to avoid deformation of crankshaft	X	X	X	X	X					
16	69 90 81 01	Tool, fitting and removing flywheel cover	X		X							
17	69 90 78 19	Tool for screw T.C.E.I. dia. 3 mm	X	X	X	X	X	X	X	X	X	X
17	69 90 24 00	Tool for screw T.C.E.I. dia. 5 mm	X	X	X	X	X	X	X	X	X	X
18	69 90 33 01	Tool, kick starter spring loading	X		X							
19	69 90 59 01	Puller, engine pinion	X		X							
20	69 90 59 00	Puller, gear transmission	X		X							
21	69 90 27 00	Puller, half crankcase clutch side	X		X							
22	69 90 78 41	Puller, gear shaft				X	X					
23	69 90 78 39	Tool, exhaust pipe rim				X	X					
24	69 90 78 37	Tool, engine pinion holdfast				X	X					

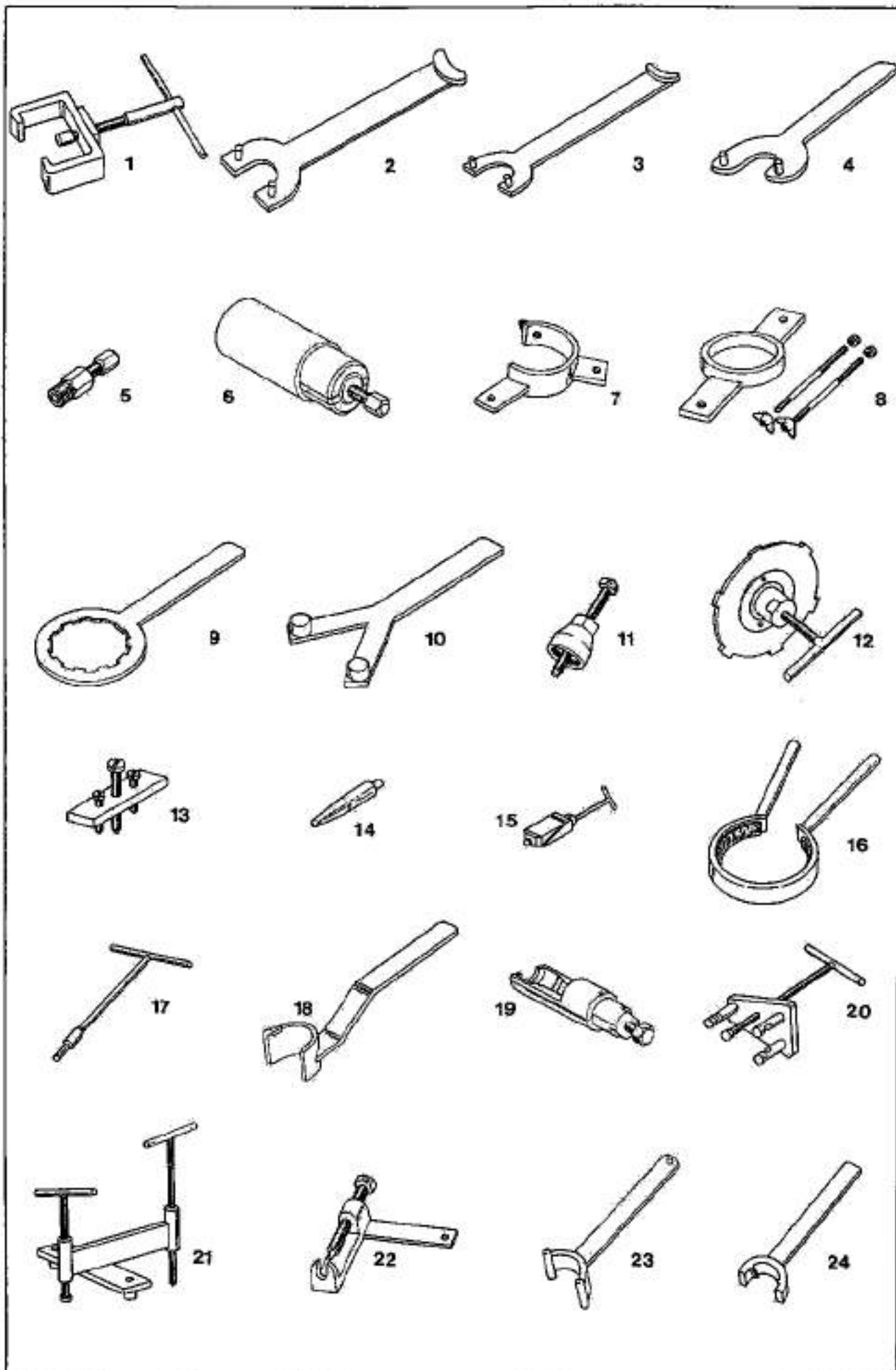

8.1 MOTORELLA - G2 WITH PEDALS - G2 ELLE G2 KS - EXPORT 3V - MAGNUM 3V

Removing the flywheel cover from the crankcase cover.

For this operation proceed as follows:

- rotate the cover in clockwise direction till the ratchet indicates the end of the turn, then slip off the cover from the crankcase.

Removing the rotating part of the flywheel

Insert in a hole of the flywheel the extremity of holdfast tool code 48 90 27 70 (2 of fig. 37) then undo the flywheel locking nut on crankshaft.

Screw in on rotating part of the flywheel tool code 43 90 63 00 (5 of fig. 37) and screw in the central screw of the tool till the detachment from the crankshaft of the rotating part.

Removing the chain pinion from transmission shaft

Remove the chain, fit on pinion holdfast tool code 48 90 27 70 (2 of fig. 37) and by means of the specific tool undo the nut fixing the pinion to the shaft.

Remove the holdfast tool and using roller code 48 91 26 70 (1 of fig. 37) slip off the pinion from the transmission shaft.

Removing the semi-automatic clutch holding plate

To remove the above plate from the crankshaft, operate as follows:

- remove the elastic ring holding the plate on crankshaft;
- fit on the plate holdfast tool for «RIMOLDI» clutch code 48 90 61 70 (10 of fig. 37);
- undo, by means of a proper wrench, the nut fixing the plate on crankshaft;
- for «RIMOLDI» clutch (fig. 38).

Fit the specific tool code 69 90 61 00 and remove the plate.

- for «ADLER» clutch (fig. 38A)

Fit the specific tool code 48 91 27 70 on the plate hub and remove the plate;

- in case of difficulties to remove the clutch housing, fit on this latter the specific tool code 69 90 33 00 (fig. 38B).

Removing the transmission shaft gear

Fit the specific tool code 48 90 61 70 (10 of fig. 37) on the gear holes and using a proper wrench undo the fixing nut from the crankshaft, then slip off the gear.

38

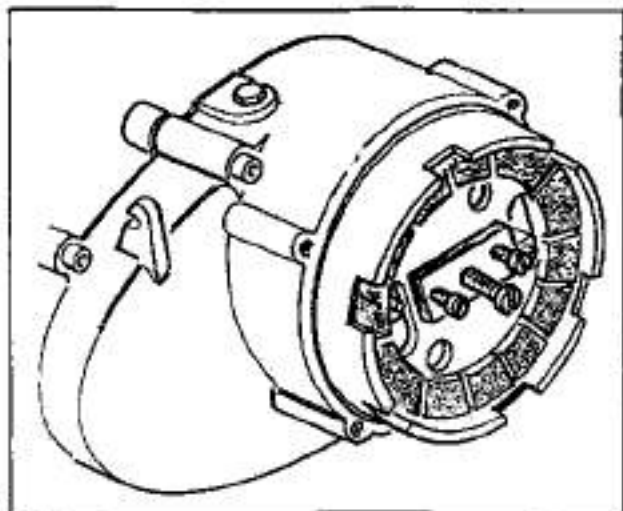

38/A

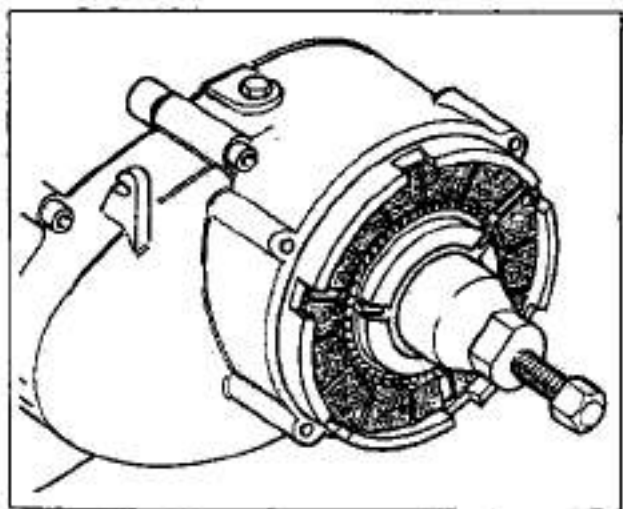

38/B

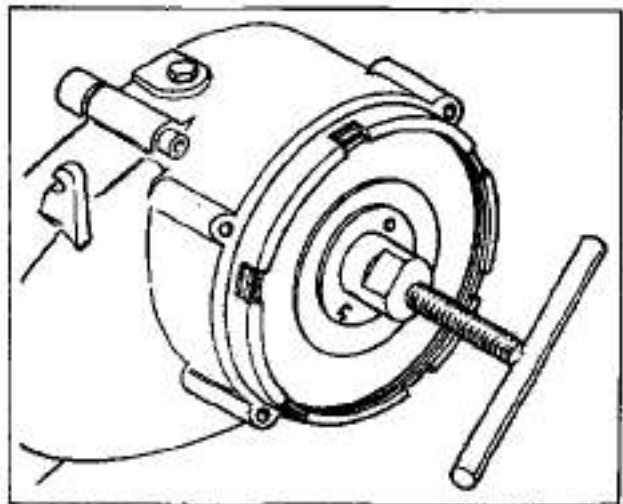

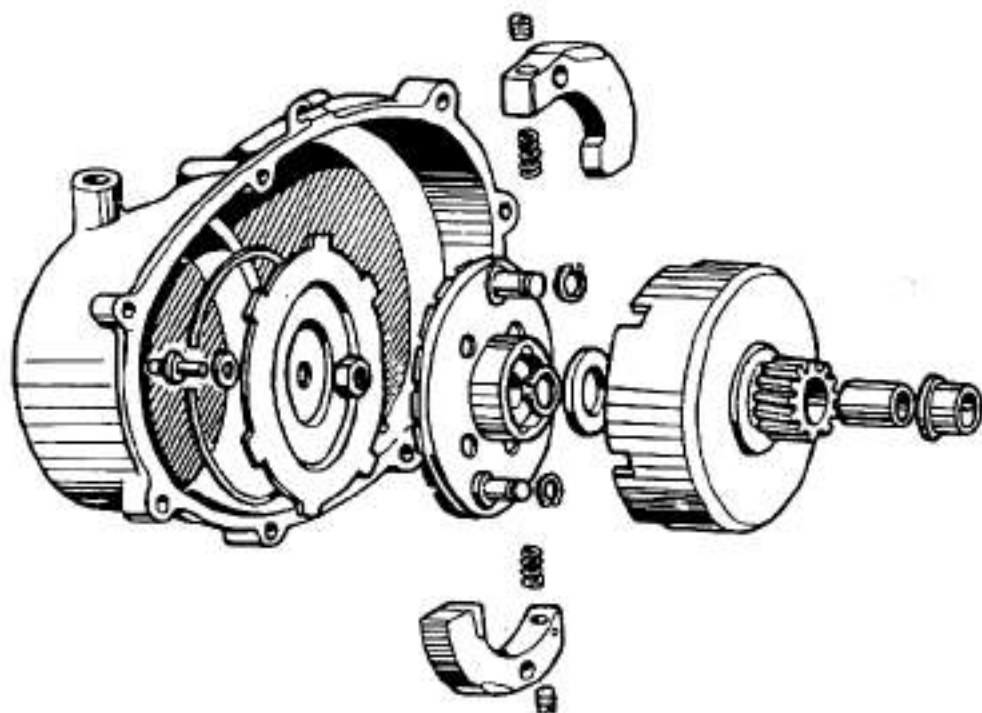

«RIMOLDI» CLUTCH

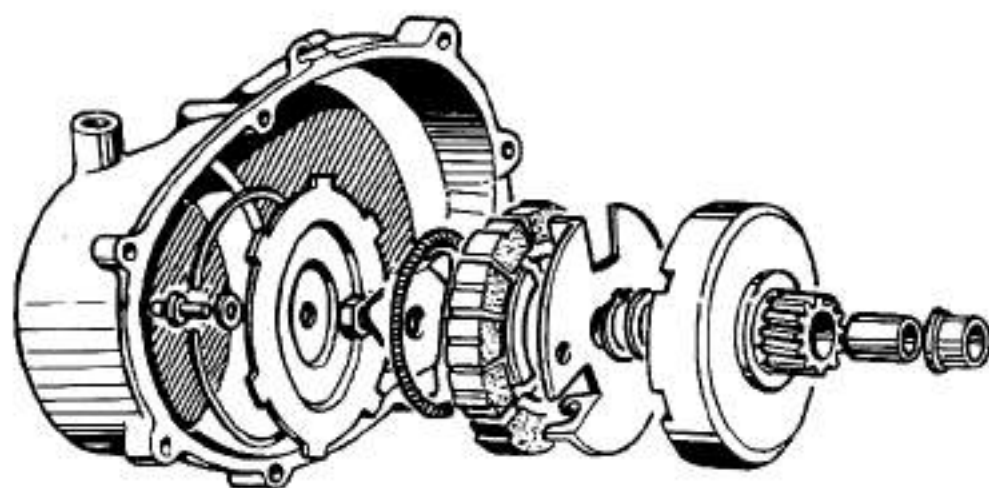

«ADLER» CLUTCH

INSPECTIONS

Cylinder for Magnum 3V and Export 3V

Ensure that the cylinder is in good conditions, without scorings, ovalization or any other wear. Otherwise replace cylinder and piston.

Standard production dia. 40.000 to 39.950 mm. For other measurements see following table.

«A» mark or 2 red dots dia. mm	«A» mark or 1 red dot dia. mm
40.000 to 39.980	39.980 to 39.970

«B» mark or no marks dia. mm	«C» mark or green dot dia. mm
39.970 to 39.960	39.960 to 39.950

Piston for Magnum 3V and Export 3V

Check that the piston is not scored or ovalized. Ensure that the piston ring seats are without carbon deposits.

Standard production dia. 40.030 to 39.990 mm. For other measurements see following table.

«A» mark or 2 red dots dia. mm	«A» mark or 1 red dot dia. mm
40.030 to 40.020	40.020 to 40.010

«B» mark or no marks dia. mm	«C» mark or green dot dia. mm
40.010 to 40.000	40.000 to 39.990

Piston rings, flywheel pin and piston pin for Magnum 3V and Export 3V

For piston rings, flywheel pin and piston pin see the measurements indicated in fig. 40.

Cylinder for Motorella - G2 KS G2 Elle and G2 with pedals

Ensure that the cylinder is in good condition, without scorings, ovalization or other wear, otherwise ream the cylinder keeping to the oversize dimensions indicated in the table.

Normal (production)

dia 40.015 to 40.025 mm

2/10 oversize

dia. 40.215 to 40.225 mm

4/10 oversize

dia. 40.415 to 40.425 mm

6/10 oversize

dia. 40.615 to 40.625 mm

Piston for Motorella - G2 KS

G2 Elle and G2 with pedals (see drawing fig. 40)

Check that the piston is not scored or ovalized and that the piston ring seats are without carbon deposits. If the cylinder has been reamed piston and piston rings have to be replaced according to the measurements of the reamed cylinder. For oversize measurements of the piston refer to the table.

Normal production dia mm	2/10 oversize dia mm
To be measured at 33 mm from piston bottom	
39.914 to 39.932	40.114 to 40.132

4/10 oversize dia. mm	6/10 oversize dia mm
40.314 to 40.332	40.514 to 40.532

Piston rings (see drawing fig. 40)

If the cylinder is reamed, together with the piston replace also the piston rings. The piston rings must be selected in the same oversize measurement as the cylinder. For this purpose see the table.

Normal production dia mm	2/10 oversize dia mm
40.000	40.200

4/10 oversize dia. mm	6/10 oversize dia mm
40.000	40.600

The clearance between piston ring and its seat on the piston must be within 0.012 and 0.045 mm.

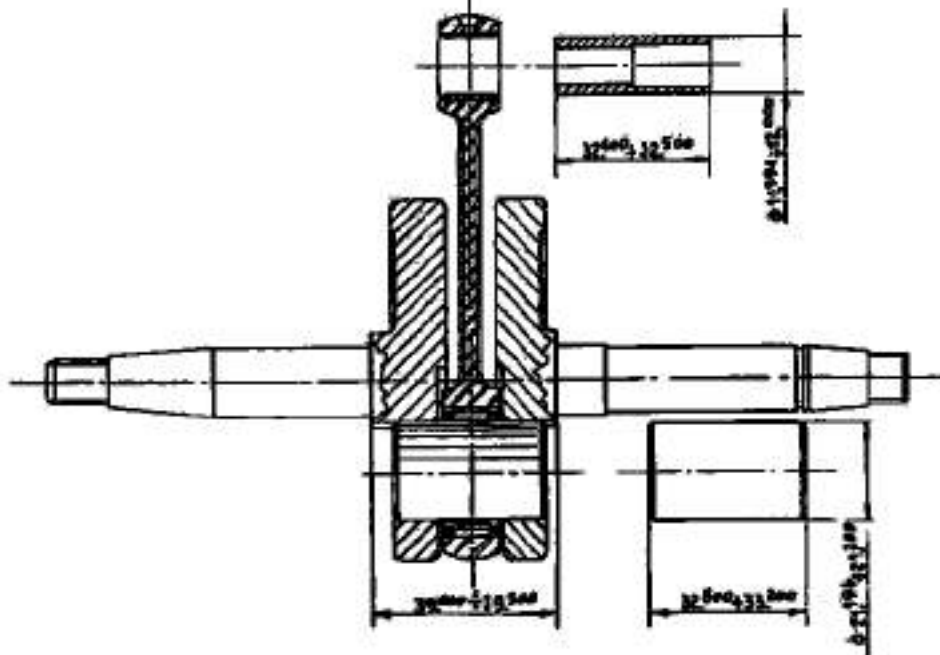
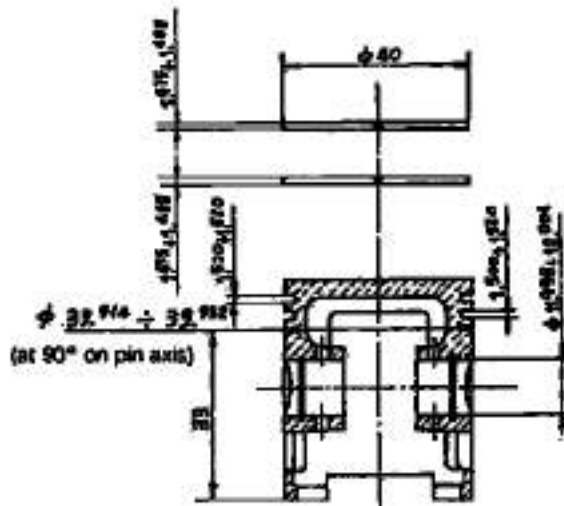
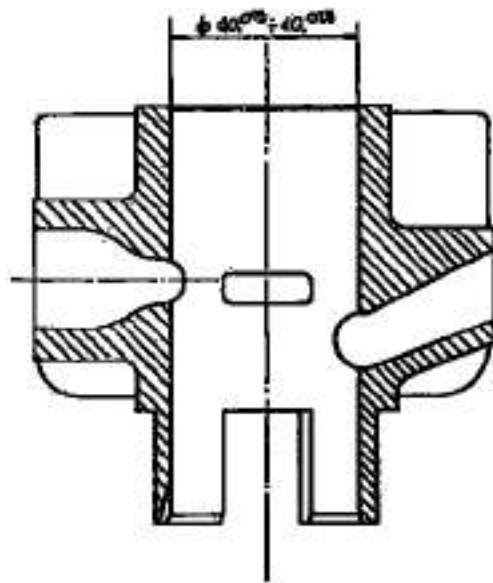

MOTORELLA G2 KS - G2 Elle - G2 with pedals

Piston pin (see drawing fig. 40)

To fit the piston pin the piston must be heated to a temperature of 60C° this is to let the piston holes expand thus allowing an easy introduction of the piston pin. The assembly allowance between piston holes and piston pin is between 0.010 mm and 0.002 mm.

Crankshaft (see drawing fig. 40)

With the crank pin fitted on both half crankshafts the clearance between pin and con rod the roller tolerance included must be within 0.015 to 0.025 mm. Distance between crank pin side and magneto flywheel locked: 39.400 to 39.500 mm (34.900 to 35.000 for Magnum 3V - Export 3V).

Fitting of cylinder and cylinder head

Do not forget to fit always a new gasket between crankcase and cylinder and between cylinder and cylinder head.

To facilitate the assembly of piston complete with piston rings into the cylinder lubricate with some engine oil the cylinder lining and the piston.

To lock the screws securing cylinders and cylinder heads to the crankcase use a 1.2 kgm loading torque wrench, following a crossed sequence.

8.2 CROSS - MAGNUM - 50 TURISMO 125 TURISMO - 125 ENDURO

Removing the covers from crankcase

Drain the oil from the engine crankcase, slacken the screws and take the gear control from the selector shaft. Undo the screws fixing the right cover to the crankcase and remove the cover same together with the seal ring; take off the kick starter pedal, undo the left cover fixing screws and remove the same.

Stripping the rotor from the flywheel

Using the special holdfast tool code 35 90 27 00 (3 of fig. 37) fit on rotor puller code 43 90 63 00 (5 of fig. 37) and screw in the central screw of the puller till the rotor is detached from the crankshaft.

Removing the engine pinion

Fit holdfast tool code 35 90 15 00 (7 of fig. 37) for 50 Turismo - Cross - Magnum or holdfast tool code 35 91 15 70 (7 of fig. 37) for 125 Turismo - 125 Enduro.

Undo the pinion securing nut and by means of puller code 35 90 63 01 (6 of fig. 37) slip off the pinion.

Removing chain pinion from layshaft

Remove the chain and fit holdfast tool on the pinion:

For 50 cc models

tool code 35 90 27 00 (3 of fig. 37)

For 125 Turismo

tool code 69 90 81 00 (4 of fig. 37)

For 125 Enduro

tool code 48 90 27 70 (2 of fig. 37).

With a proper wrench undo the nut securing the pinion to the shaft; should it be necessary use the special puller provided for this purpose.

Stripping the clutch assy from the gear box main shaft

Fit holdfast tool code 35 90 61 00 (9 of fig. 37) on the clutch plate holder; with a proper wrench unscrew the nut and slip off the shim and the spring. Remove the seeger ring, plate holder and plates. For the re-assembly operation reverse this sequence bearing in mind to pull the clutch lever that much to allow the fitting of the seeger ring on the plate holder. Furthermore to screw the nut on the main shaft it is necessary to use the specific tool code 35 90 65 00 (8 of fig. 37) to press the shim against the spring thus making it possible to screw the nut in.

INSPECTIONS

CYLINDER

Ensure that there are not scorings or ovalizations, otherwise replace cylinder and piston.

CYLINDER SELECTION TABLES

CROSS - MAGNUM - 50 TURISMO (fig. 41)

«A-A» mark or 2 red dots dia. mm	«A» mark or 1 red dot dia. mm	«B» mark or no marks dia. mm	«C» mark or green dot dia. mm
40.030 to 40.020	40.020 to 40.010	40.010 to 40.000	40.000 to 39.990

125 TURISMO - 125 ENDURO (fig. 42)

«A-A» mark or 2 red dots dia. mm	«A» mark or 1 red dot dia. mm	«B» mark or no marks dia. mm	«C» mark or green dot dia. mm
56.040 to 56.030	56.030 to 56.020	56.020 to 56.010	56.010 to 56.000

PISTON

Ensure that there are no bad scorings so as to compromise its good working conditions. Otherwise replace the piston by choosing one of the same selection of the cylinder, providing also the cylinder is in good working conditions.

PISTON SELECTION TABLE

CROSS - MAGNUM - 50 TURISMO (fig. 41)

«A-A» mark or 2 red dots dia. mm	«A» mark or 1 red dot dia. mm	«B» mark or no marks dia. mm	«C» mark or green dot dia. mm
40.000 to 39.990	39.990 to 39.970	39.970 to 39.960	39.960 to 39.950

MATCHING POINT (selection dia.) at 35 mm from piston bottom

125 TURISMO - 125 ENDURO (fig. 42)

«A-A» mark or 2 red dots dia. mm	«A» mark or 1 red dot dia. mm	«B» mark or no marks dia. mm	«C» mark or green dot dia. mm
55.940 to 55.931	55.930 to 55.921	55.920 to 55.911	55.910 to 55.901

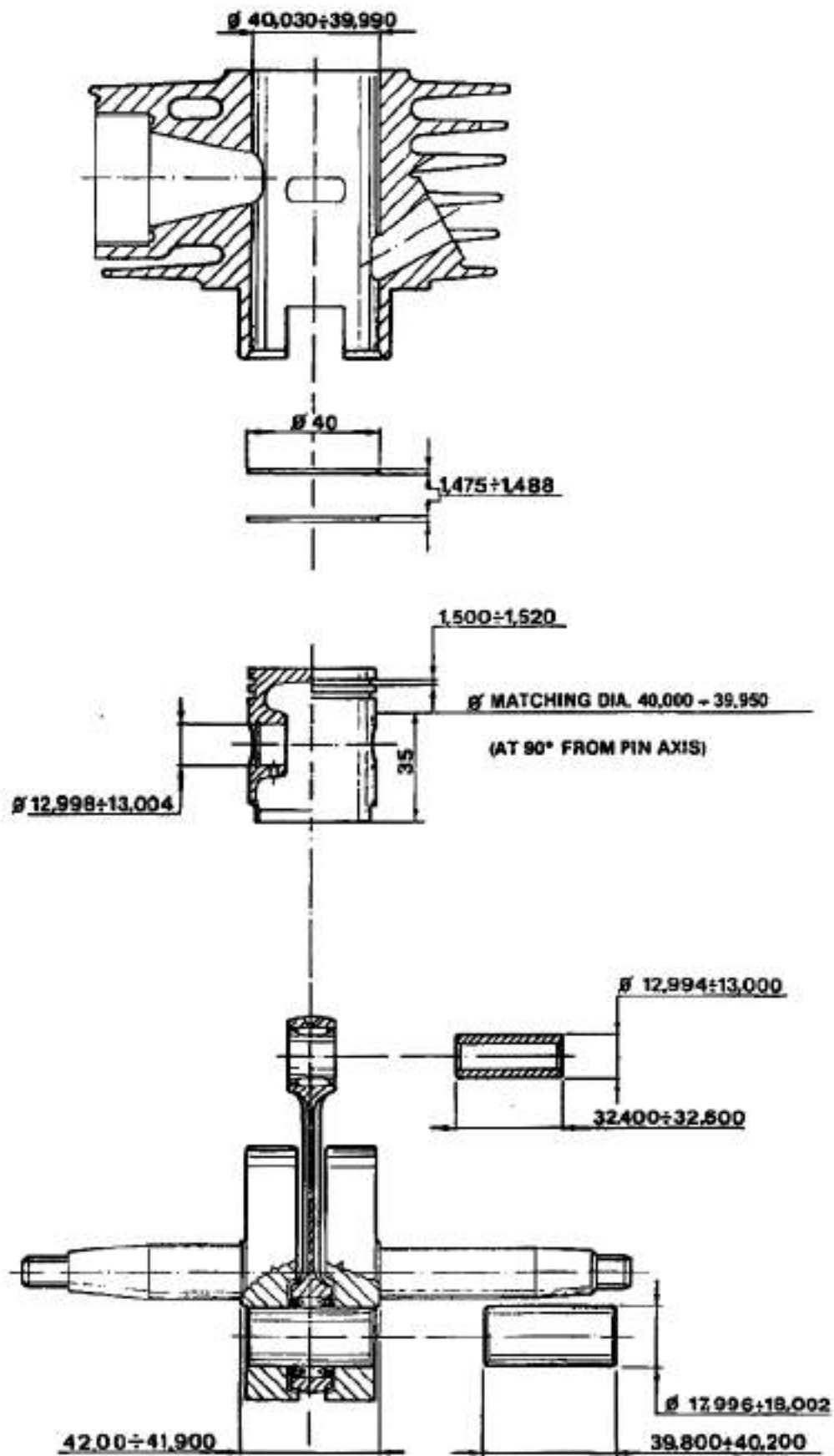

50 TURISMO · CROSS · MAGNUM

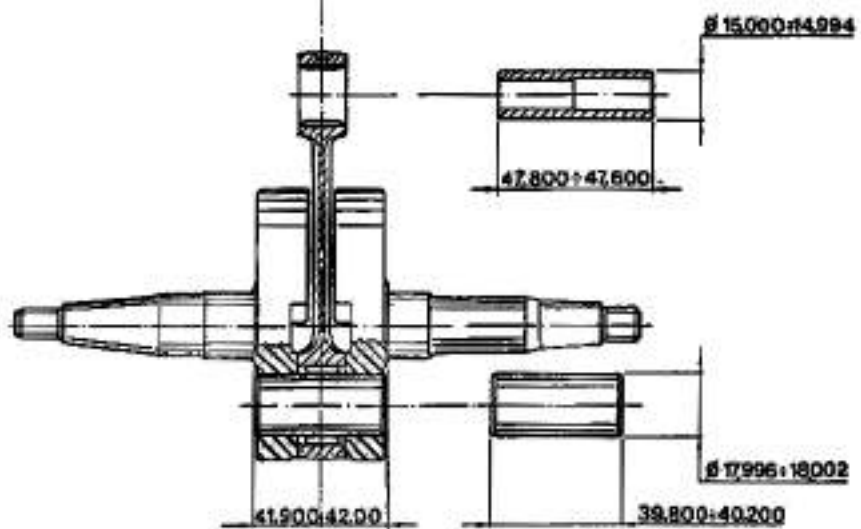
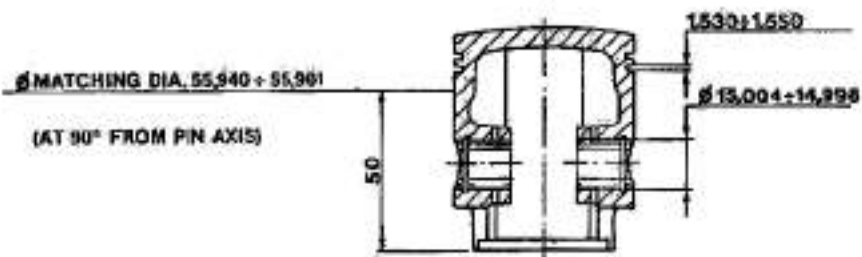
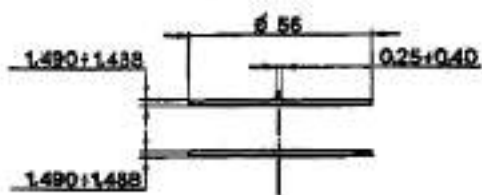
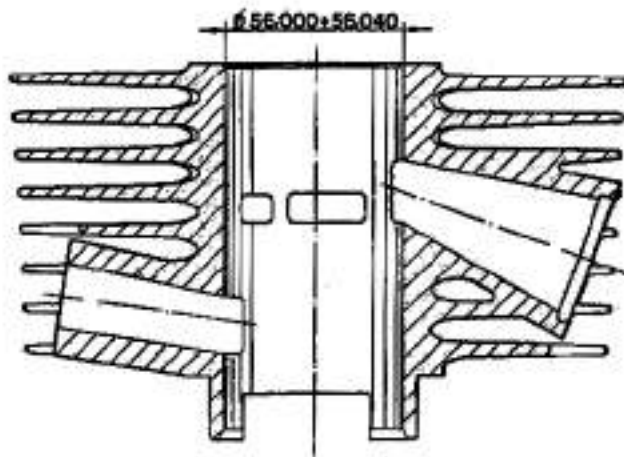

125 TURISMO - 125 ENDURO

Matching point (selection dia.)
at 50 mm from piston bottom.

PISTON RINGS

CROSS - MAGNUM - 50 TURISMO (fig. 41)

Ring dia 40 mm, thickness 1.488 to 1.475 mm.
Side play between piston ring and piston ring seat:
between 0.012 to 0.045 mm.

125 TURISMO - 125 ENDURO (fig. 42)

Ring dia. 56 mm, thickness 1.490 to 1.488 mm.
Side play between piston ring and piston ring seat:
between 0.040 to 0.062 mm.

Piston pin

Heat the piston to a temperature of 60°C (in an oven) before fitting the piston pin. This will allow a light expansion of piston pin holes thus allowing an easy introduction of the piston pin.

CROSS - MAGNUM - 50 TURISMO (fig. 41)

- piston pin holes on piston: dia. 13.004 to 12.998 mm.
- piston pin: dia. 13.000 to 12.994 mm.

125 TURISMO - 125 ENDURO (fig. 42)

- piston pin holes on piston: dia. 15.004 to 14.998 mm
 - piston pin: dia. 15.000 to 14.994 mm.
- Coupling clearance between piston and piston pin:
0.010 mm to a negative clearance of 0.002 mm.

Crankshaft

With crank pin fitted on the two crankshaft halves the clearance between crank pin and con rod, the roller clearance included, is 0.015 to 0.025 mm.
Distance between shoulder sides (crank pin and magneto flywheel locked): 41.900 to 42.000 mm.

Re-assembly of cylinder-cylinder head on crankcase

Always replace the gasket between crankcase and cylinder and between cylinder and cylinder head.
To facilitate the assembly of piston complete with piston rings into the cylinder lubricate the cylinder lining and piston with some engine oil.
To lock the four screws securing cylinders and cylinder heads follow a cross sequence. Use a 1.2 loading torque wrench for 50 Turismo - Cross - Magnum and a 2.5 kgm for 125 Turismo - 125 Enduro.

9.1 STRIPPING THE GEARBOX

1 — Undo the screws fixing the crankcases half. Attention: do not forget the two screws of the crankcase under the clutch housing and the four screws of the crankcase under the magneto flywheel stator plate.

2 — Before separating the two crankcase halves.

a. remove the selector ass.y

b. unscrew the lock screw of the start gear under the right crankcase.

3 — With the aid of a rubber hammer lightly tap on the crankshaft and on the chain pinion shaft so as to separate the two crankcase halves.

9.2 STRIPPING THE SHAFTS: MAINSHAFT, LAYSHAFT AND SPLINED SHAFT COMPLETE FROM THE RIGHT CRANKCASE

Once the two crankcases have been separated, the mainshaft, layshaft and splined shaft remain on the right crankcase half, to slip them off operate as follows:

- using a mallet and a punch lightly tap on the layshaft so as to slip off at the same time the shafts from the right crankcase half. Pay attention to the assembly order of the adjusting shims on the mainshaft.

9.3 ASSEMBLY

For the assembly revert the stripping sequence paying attention to the following:

- the first speed gear has to be assembled according to sketch «1» of fig. 44;

- to fit between the crankcases halves and layshaft the adjusting shim «A» and «B» according to sketch of fig. 44;

- to assemble gears «2» and «4» correctly (see sketch of fig. 44).

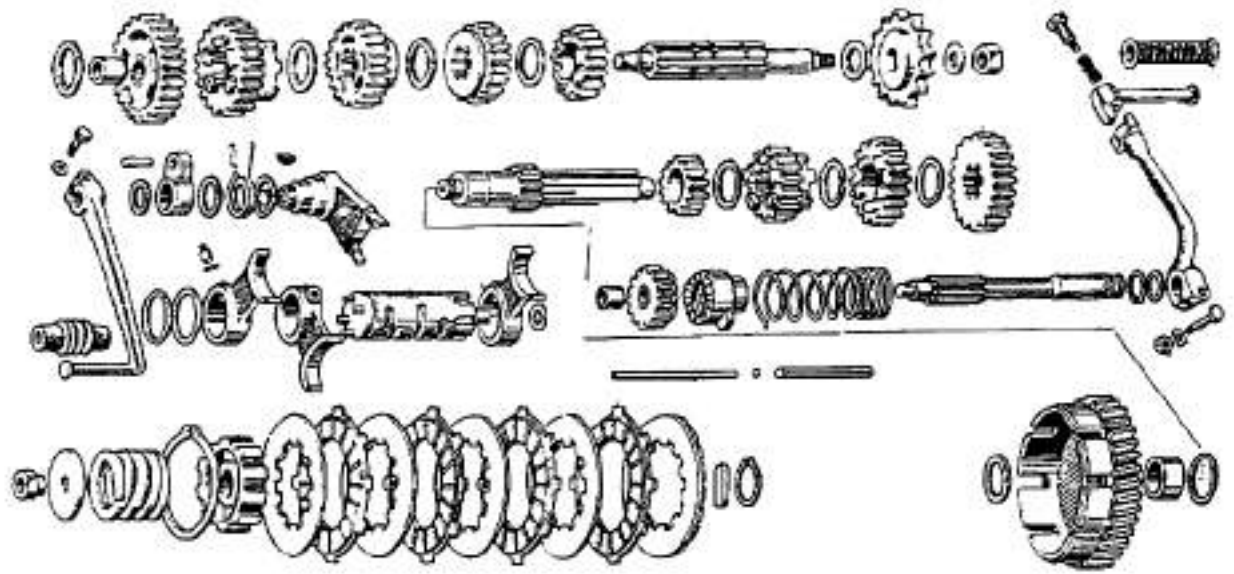

43

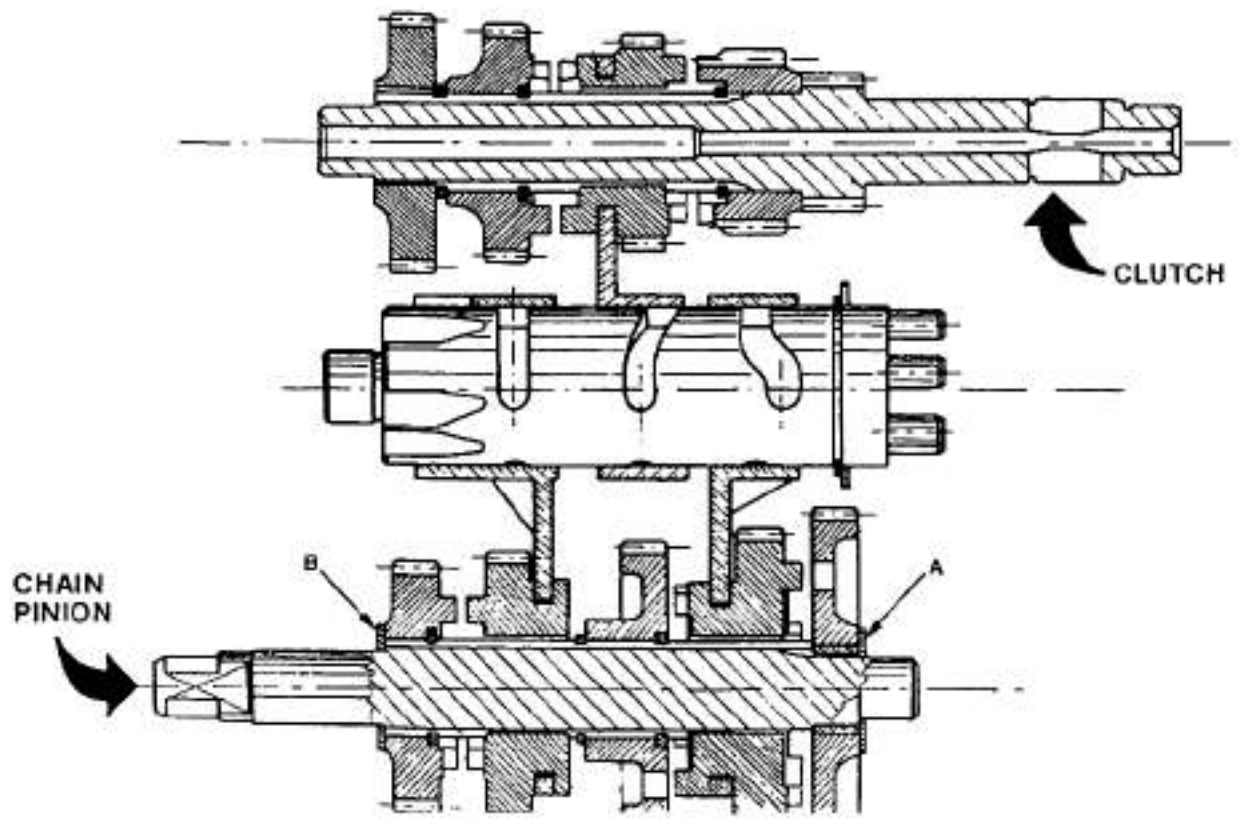

5 SPEED GEARBOX
(with splined shaft control)

«A» and «B» adjusting washers

44

10 VALVE GEARING

ENGINE TIMING DIAGRAM (fig. 45)

10.1 G2 KS · G2 ELLE · G2 WITH PEDALS

A — Inlet	116° ±2°
B — Exhaust	124° ±2°
C — Decantation	98° ±2°
D — Ignition advance	29°

10.2 MOTORELLA

A — Inlet	96° ±2°
B — Exhaust	124° ±2°
C — Decantation	98° ±2°
D — Ignition advance	29°

10.3 EXPORT 3V · MAGNUM 3V

A — Inlet	125° ±2°
B — Exhaust	145° ±2°
C — Decantation	118° ±2°
D — Ignition advance	28°

10.4 50 TURISMO · CROSS · MAGNUM

A — Inlet	144° ±2°
B — Exhaust	168° ±2°
C — Decantation	120° ±2°
D — Ignition advance	20°

10.5 125 TURISMO · 125 ENDURO

A — Inlet	157° ±2°
B — Exhaust	170° ±2°
C — main	120° ±2°
secondary	115° ±2°
D — Ignition advance	20°

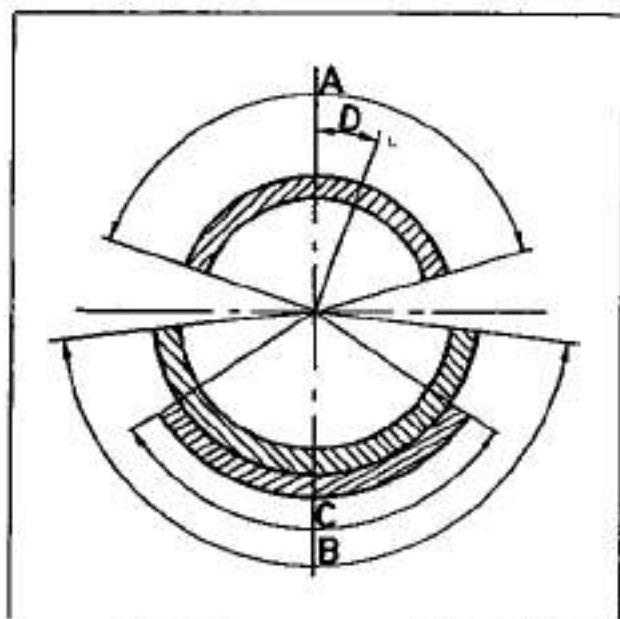

45

11.1 MOTORELLA - G2 KS - G2 ELLE G2 with pedals - 50 TURISMO

Carburettor Dell'Orto type «SHA 14» equipped with air filter and air funnel silencer.

Carburettor control (fig. 46)

The choke valve on the carburettor is controlled by the R/H twist grip on the handlebar through a flexible cable.

The starter is controlled by a lever fitted on the L/H side of the carburettor.

Lever position:

- «A» cold engine starting
- «B» riding position

Standard carburettor setting

Choke	dia. 9 mm (Motorella - G2 KS - G2 Elle - G2 with pedals - Magnum)
	dia. 12 mm (50 Turismo - Export 3V - Magnum 3V - Cross)
Main jet	44 (G2 KS - G2 Elle - G2 with pedals)
	45 (Motorella)
	48 (Magnum)
	52 (Export 3V - Magnum 3V)
	58 (Turismo - Cross)
Floater	3.5 gr.

Adjusting the idling speed (fig. 46)

This adjustment is done with the throttle control at the minimum position and when the engine is warm. The bike off the stand (the wheels touching the floor). Start the engine and turn adjusting screw «C» to obtain the max rev possible before the bike starts moving.

The above is valid for model G2 with pedals; for models G2 KS - G2 Elle - Motorella - 50 Turismo - Cross - Magnum - Export 3V act on adjuster screw «C» to obtain a regular and uniform engine operating speed.

Carburettor components (fig. 47)

- 1 Float pin
- 2 Air funnel gasket
- 3 Air valve pin
- 4 Air valve
- 5 Return spring, air valve
- 6 Filter, fuel
- 7 Banjo union
- 8 Banjo union fixing screw gasket
- 9 Fixing banjo union screw
- 10 Locking screw manifold nut
- 11 Throttle valve return
- 12 Throttle gasket valve cover
- 13 Throttle valve cover
- 14 Fixing throttle valve cover screw
- 15 Cable nut
- 16
- 17
- 18
- 19
- 20
- 21
- 22
- 23
- 24
- 25
- 26
- 27
- 28
- 29
- 30

46

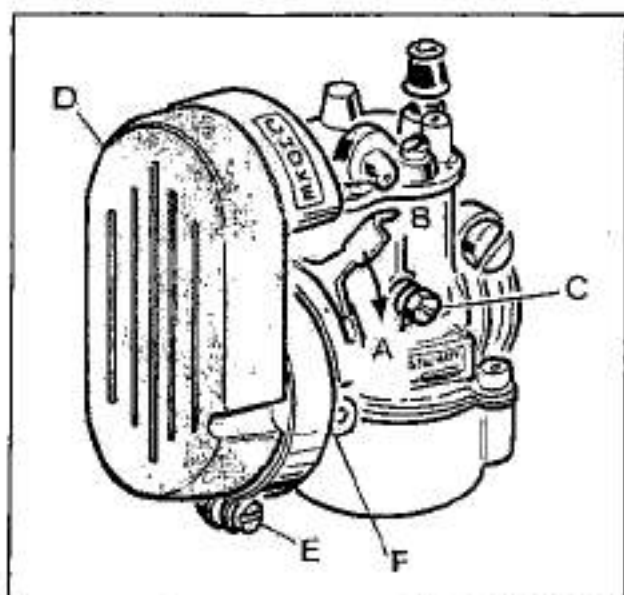

47

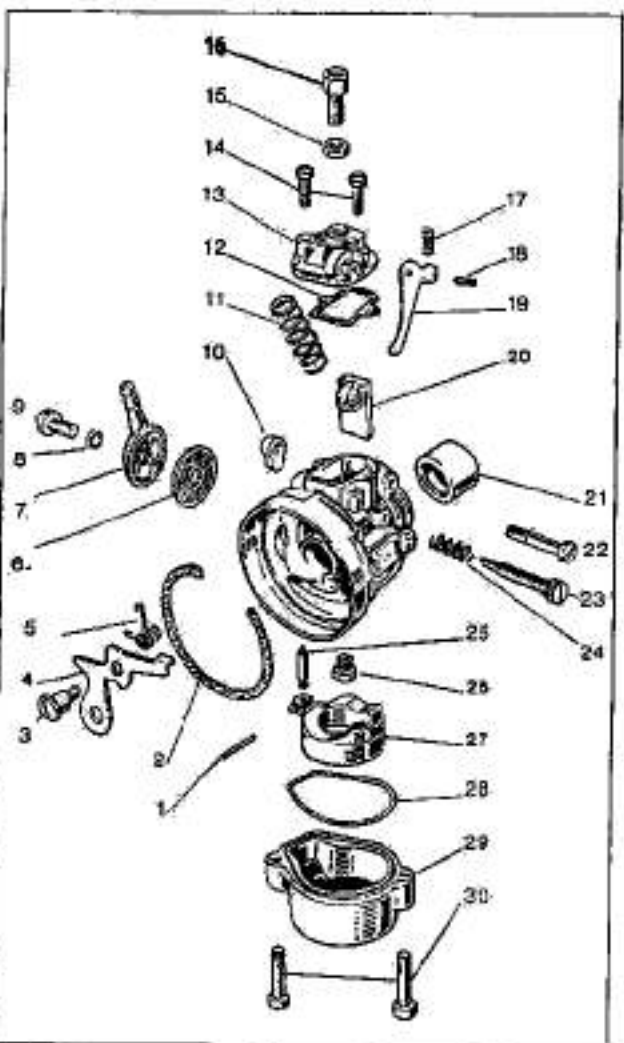

- 16 Cable adjuster
- 17 Return spring, air valve lever
- 18 Lever pin
- 19 Air valve lever
- 20 Throttle valve
- 21 Insulator adaptor
- 22 Manifold fixing screw
- 23 Adjusting screw, throttle valve
- 24 Spring, adjusting screw
- 25 Needle
- 26 Main jet
- 27 Float
- 28 Gasket float chamber
- 29 Float chamber
- 30 Screw, fixing float chamber

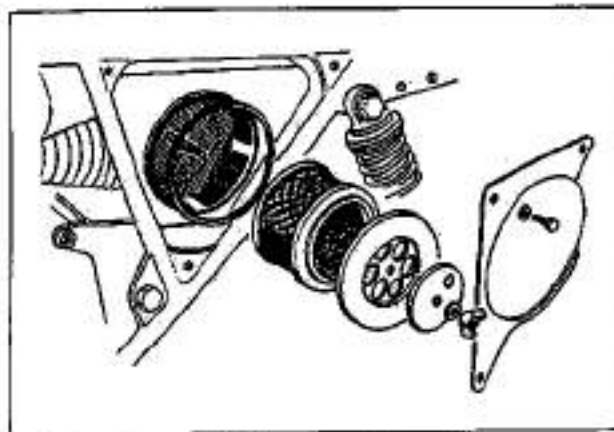

48

Intake silencer with air filter

(fig. 46)

This has to be cleaned every 2000 km or more frequently if the bike is used on dusty roads. For this operation proceed as follows:

- remove intake silencer «D» on the carburettor after undoing clamp «E» locking screw;
- slip off from carburettor filter «F»;
- wash in gasoline bath and dry with compressed air the intake silencer and air filter;
- re-assemble everything reverting the above sequence.

N.B. - Model «Cross» is equipped with a paper air filter (see fig. 48); therefore this has to be cleaned with compressed air every 1000 km and changed every 5000 km.

Cleaning filters on fuel tap and carburettor

When cleaning filter «B» of fig. 49 and intake filter «D» of fig. 46, it is advisable to clean also the filter «A» on fuel tap and filter «C» on carburettor (fig. 49) operating as follows:

- take out the pipe carrying the fuel from the tap on the tank and empty the tank;
- remove the fuel tap from tank;
- undo the screw and remove the pipe from carburettor and then take out filter «C»;
- in a cleaned gasoline bath wash fuel tap filter «A» and the filter on carburettor «C», then dry with a compressed air jet the filters, the fuel tap ducts and the pipe carrying the fuel to the carburettor.

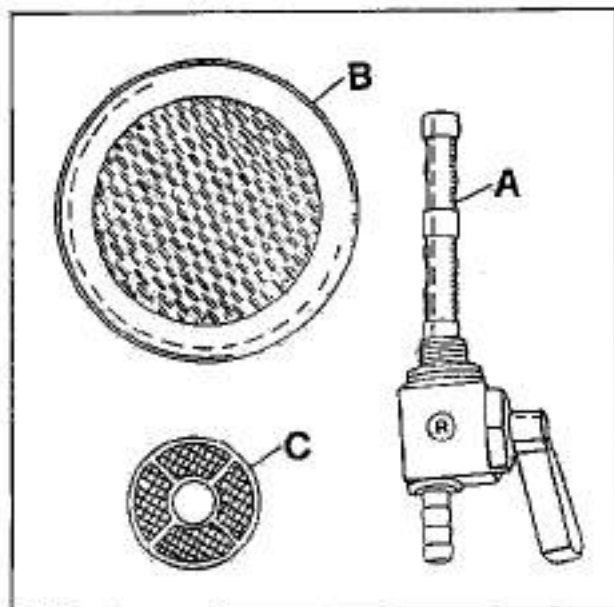

49

11.2 125 TURISMO - 125 ENDURO

Carburettor controls

- throttle control grip on the R/H side of the handlebar;
 - cold engine starting lever «Starter» (fig. 50)
- «A» cold engine starting position
 «B» riding position

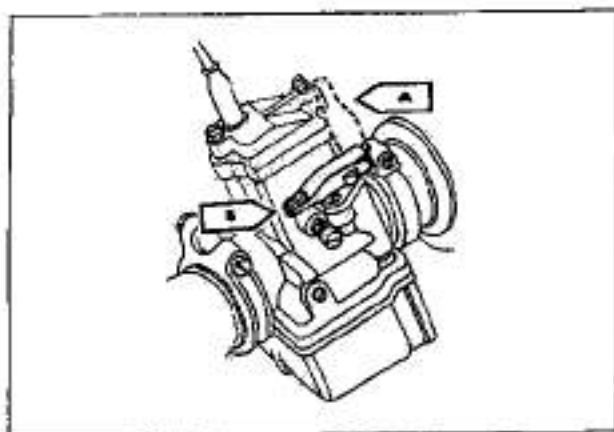

50

51

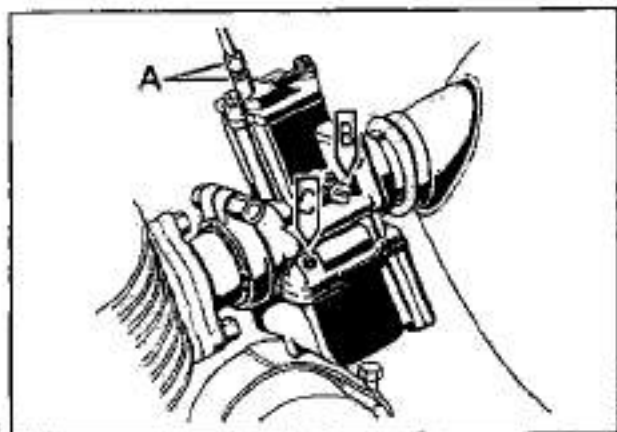

Adjusting idling position (fig. 51)

This adjustment has to be done with warm engine operating as follows:

- Ensure that the throttle control cable at the carburettor has a free play of 1 to 1.5 mm, otherwise act on adjusting screw and counter-nut «A» to obtain this play.
- Adjust throttle valve screw «B» to obtain a lively idling speed.
- Tighten screw «C» adjusting the idling speed fuel supply till the engine seems to stop and undo the same screw till the engine turns regularly.
- Operate again on throttle valve screw «B» to obtain the desired idling speed.

Standard carburettor setting (fig. 52)

Carburettor Dell'Orto VHB 22 BS

- A Throttle 60
- B Atomizer 260 S
- C Main jet 72 (125 Turismo)
- C Main jet 75 (125 Enduro)
- D Needle E 20 (2nd notch)
- E Idling jet 48
- F Starter jet 70
- G Float 10 gr

FLOAT LEVEL

Ensure that the float weight is as recommended and indicated on the float itself and the float rotates freely on its pin.

Keep the carburettor body as indicated so that the float balance slightly touches the needle and the needle slightly touches the seat.

Under this condition check if the two float halves are of the fixed measure in respect of the body plane: 23.5 mm (fig. 53).

Carburettor components (fig. 54)

Carburettor Dell'Orto «VHB 22 BS»

- 1 Idling speed adjusting screw
- 2 Adjusting screw spring
- 3 Throttle valve adjusting screw
- 4 Adjusting screw spring
- 5 Air intake adaptor
- 6 Screw fixing starting device
- 7 Starting device
- 8 Starting device gasket
- 9 Throttle valve cover fixing screw
- 10 Washer
- 11 Throttle valve cover
- 12 Throttle valve cover gasket
- 13 Cap
- 14 Cable adjuster
- 15 Cable adjuster nut
- 19 Throttle valve spring
- 20 Needle «E»

52

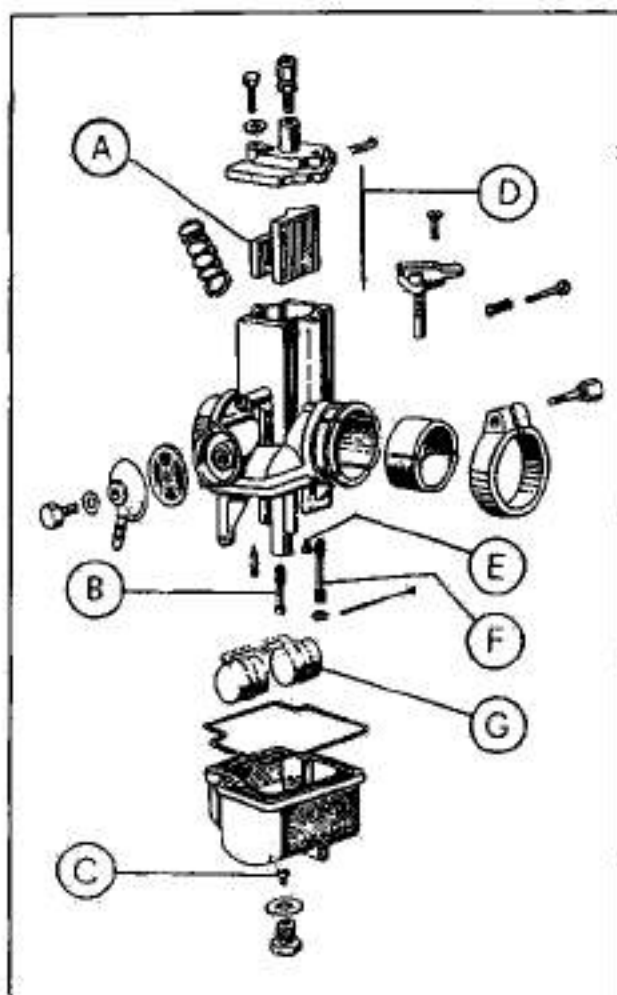

53

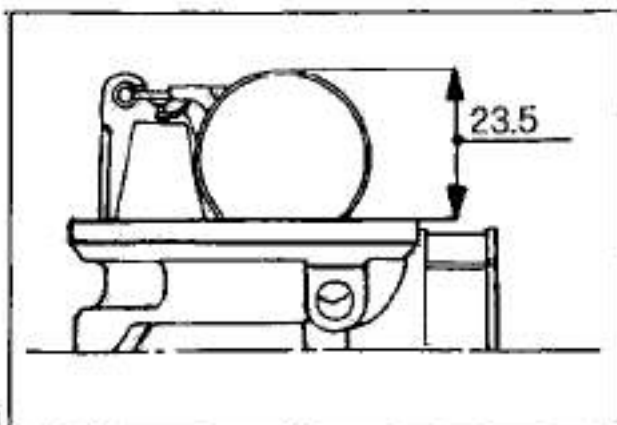

- 21 Needle clip
- 22 Throttle valve
- 23 Lockring clip
- 24 Clip
- 25 Clip locking screw
- 26 Insulating rubber
- 32 Starter jet
- 33 Starter jet gasket
- 34 Atomizer
- 35 Idle jet
- 36 Fuel needle
- 37 Float
- 38 Fuel filter
- 39 Banjo union
- 40 Banjo union gasket
- 41 Banjo union screw
- 42 Float pin
- 43 Float chamber gasket
- 44 Float chamber
- 45 Float chamber plug gasket
- 46 Main jet
- 47 Floater chamber plug

Cleaning fuel tap filter and carburettor filter

Periodically it is advisable to clean fuel tap filter «A» and carburettor filter «C»; see fig. 49 operating as follows:

- remove fuel tap pipe and empty fuel tank;
- remove fuel tap from tank;
- remove banjo union, after undoing fixing screw, from carburettor; then remove filter «C» of fig. 49;
- in a gasoline bath wash fuel tap filter «A» and carburettor filter «C»; dry with compressed air jets the filters and also the tap ducts and the pipes carrying the fuel to the carburettor.

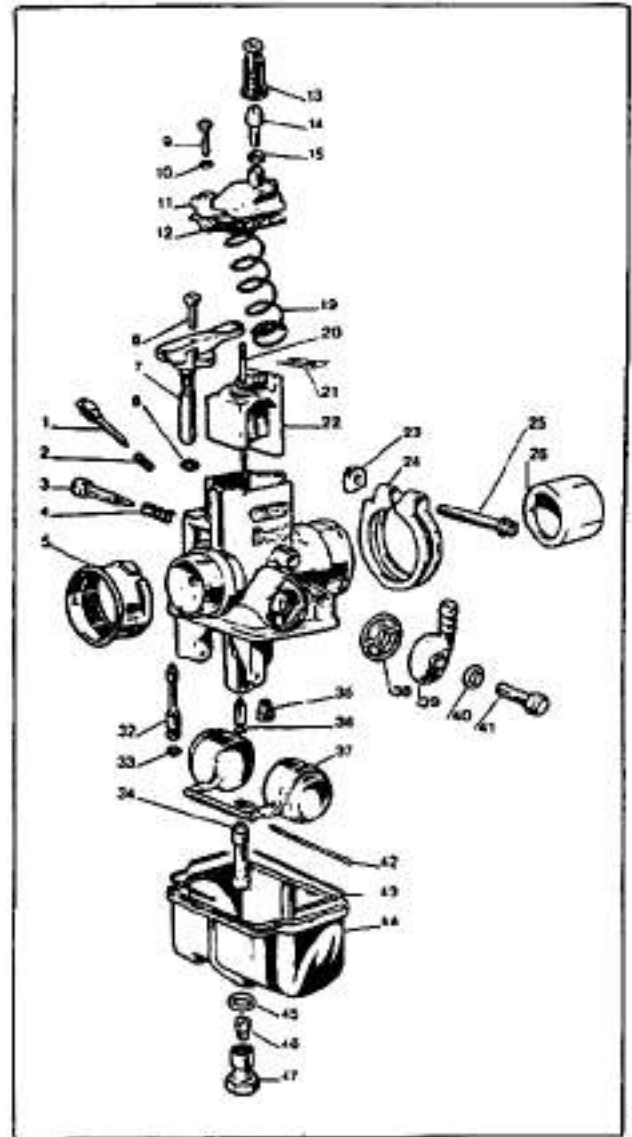

12.1 MOTORELLA - G2 WITH PEDALS G2 ELLE - G2 KS - MAGNUM 3V - EXPORT 3V

Gearbox lubrication Oil level control (fig 55)

Every 500 km check if the oil level is nearly up to inspection hole «A». If necessary top up with oil of the same quality and density.

Replacing the oil (fig 55 - 55/A)

This replacement has to be done on a warm engine after the first 500 km and then every 5000 km. Introduce fresh oil only when the old one is completely drained.

«A» inspection hole plug
«B» filler cap (only for Export 3V and Magnum 3V)
«C» drain plug

Quantity required: 0.110 kg for G2 with pedals; 0.160 kg for Motorella, G2 KS, G2 Elle; 0.360 kg for Export 3V, Magnum 3V; oil «Agip F 1 Motoroil HD SAE 20W/30».

Chains lubrication

Lubricate the chains every time they appear to be dry.

This operation has to be done every 5000 km about and more frequently if the bike is used on dusty roads and in raining days.

It is advisable to wash the chains in a petrol bath, carefully dried and greased with «Agip F.1 Grease 30».

For normal lubrication (every 500 km) it is advisable to use «Agip Rocol Chain Lube Spray» specially produced for this purpose.

Other lubrications

Every 10000 km

- Disassemble the steering assy and check caps and balls; wash them in a petrol bath and ensure that they are in good working conditions then lubricate (fig. 56).

- Remove the wheels. Carefully clean caps and balls and ensure that they are in good conditions; fill the caps with grease and refit the balls.

When reassembling the wheels carry out their adjustment paying attention to leave a small play in order that the wheel can turn freely (fig. 57).

Periodically lubricate joints and control cables.

For the above operation we suggest to use grease «Agip F.1 Grease 30».

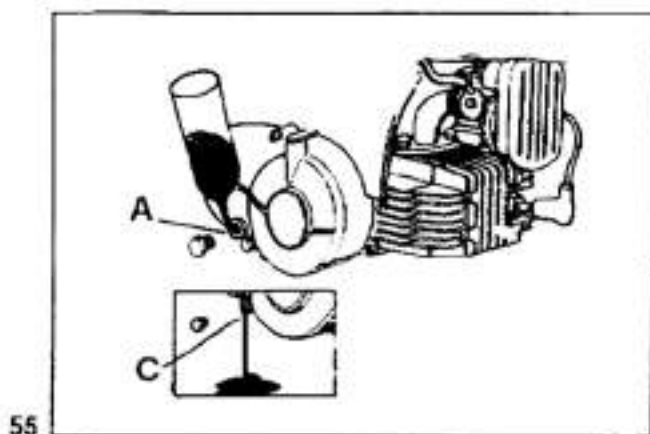

55

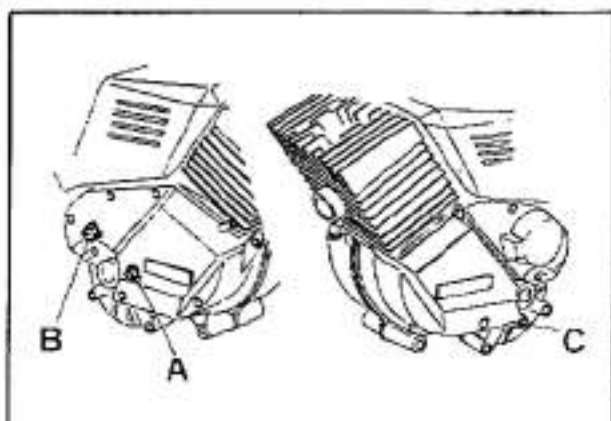

55/A

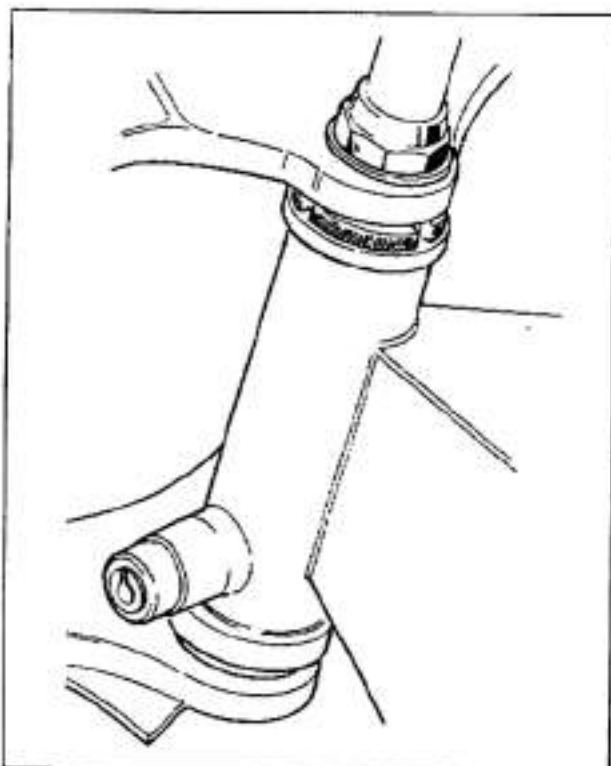

56

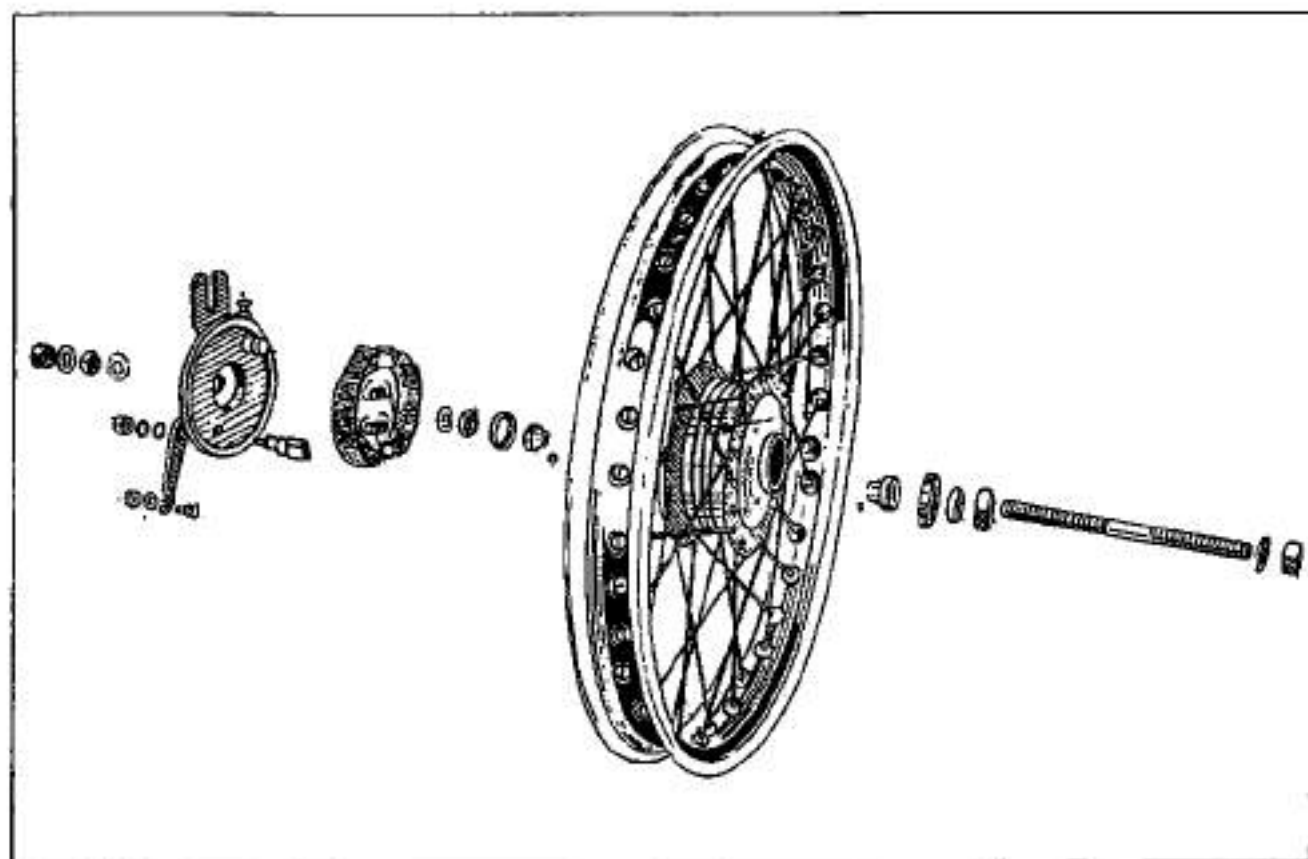

57

12.2 50 TURISMO · CROSS · MAGNUM 125 TURISMO · 125 ENDURO

Engine lubrication

The life and efficiency of the engine and bike components depend mainly on the lubrication. It is therefore important to carefully follow the instructions hereafter.

Oil level inspection (fig. 58)

Periodically check the oil level in the gearbox. the oil has to nearly reach the lower side of the filling hole (upper hole indicated in the figure) Should the oil be under this level, add oil of the recommended type. It is advisable not to overfill the gearbox in order to avoid the clutch becoming too hard and the oil to leak out through the breather tube because of too much pressure.

Changing the oil (fig. 58)

After the first 1000 to 1500 km and at 6000 km intervals or so, change the oil in the gearbox. This change will be carried out with a warm engine proceeding as follows:

- place a container under the crankcase to catch the oil, loosen the caps indicated in the figure.
- when the oil is completely drained re-fit the caps and introduce 0.500 kg of oil «Agip F.1 Motoroil HD SAE 20W/30».

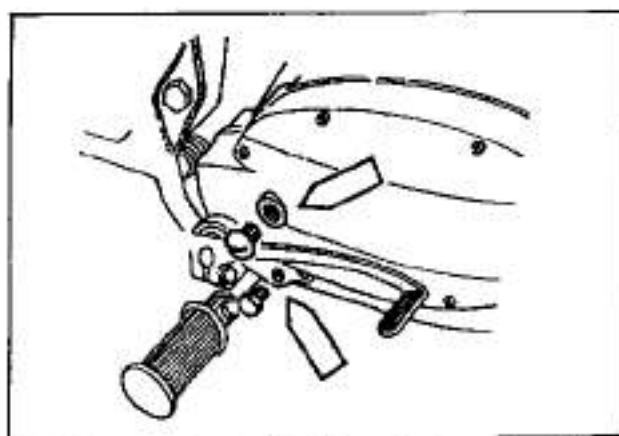

58

59

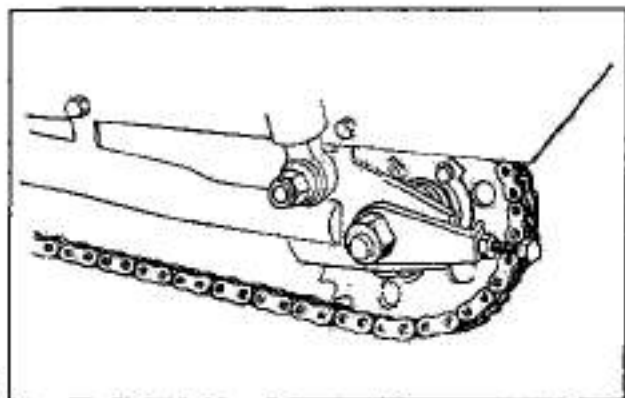

Chain Lubrication (fig. 59)

This has to be lubricated every time it appears to be dry. This operation must be done every 5000 km or so or more frequently if the bike is used in rainy days or in dusty roads.

It is advisable to wash the chain in a petrol bath, to dry and grease it with «Agip F.1 Grease 30».

For normal lubrication (every 500 km) it is advisable to use «Agip Rocol Chain Lube Spray» specially produced for this purpose.

Front fork lubrication (fig. 60)

Every 10000 km about or whenever necessary replace fork tube oil proceeding as follows:

- remove oil drain plugs «B» and filling plugs «A»; completely drain the oil by pumping the fork;
- reinstall oil drain plugs complete with gasket «B» and introduce «Agip F.1 ATF Dexron» fluid in each fork tube;
- operate several times the fork to let the oil go inside the fork, then reinstall filling plugs. Fluid necessary for each fork tube:
- 0,130 l for 50 Turismo - Cross fitting 1st serie fork
- 0,150 l for 50 Turismo - Cross fitting 2nd serie fork
- 0,160 l for Cross 1976
- 0,140 l for 125 Turismo
- 0,180 l for 125 Enduro.

60

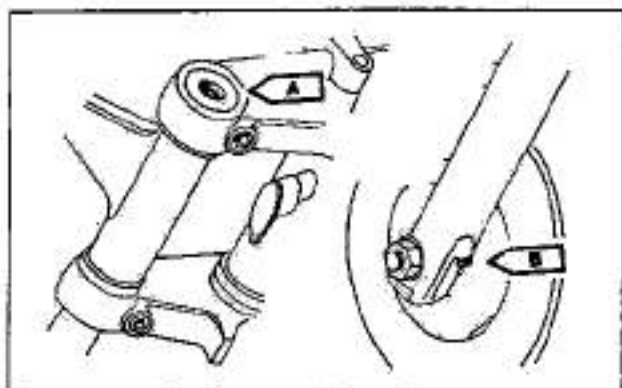

Other lubrications

- Every 10000 km lubricate wheel bearings.
 - Periodically lubricate speedometer driving gear.
 - For 125 Enduro lubricate, every 2500 km swinging arm joint through the greaser located under the swinging arm.
 - Lubricate rear brake control pedal pin.
- Use grease «Agip F.1 Grease 30».

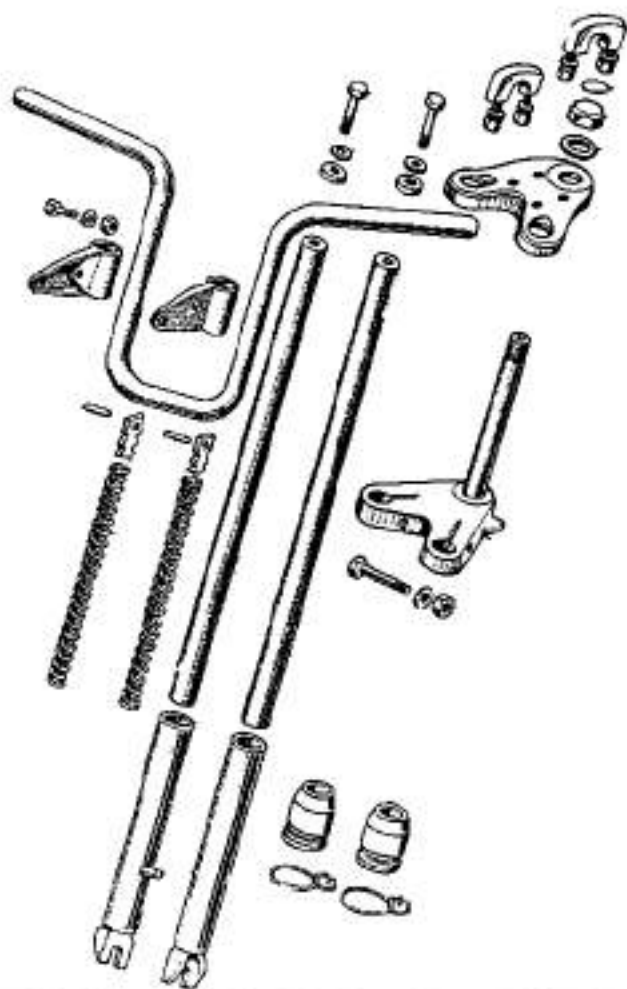

50 MAGNUM

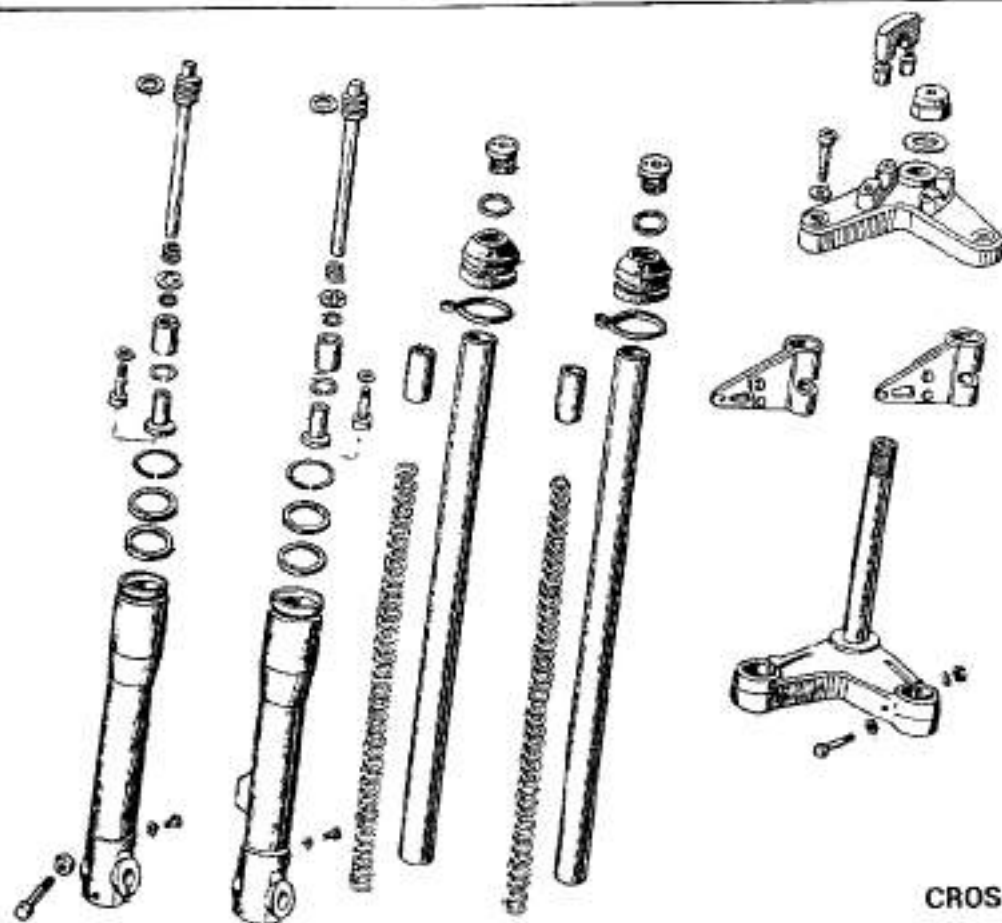

CROSS 50-1976

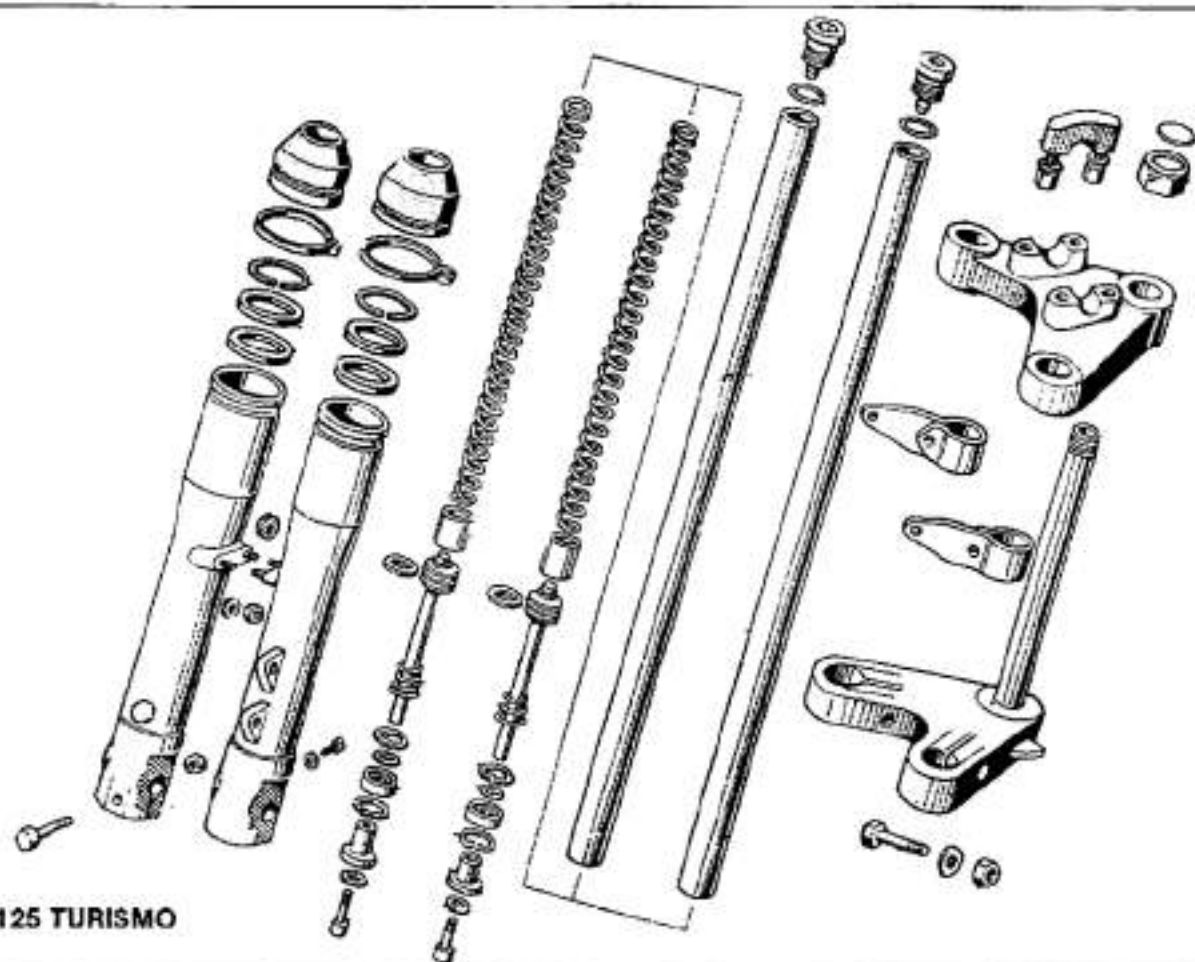

125 TURISMO

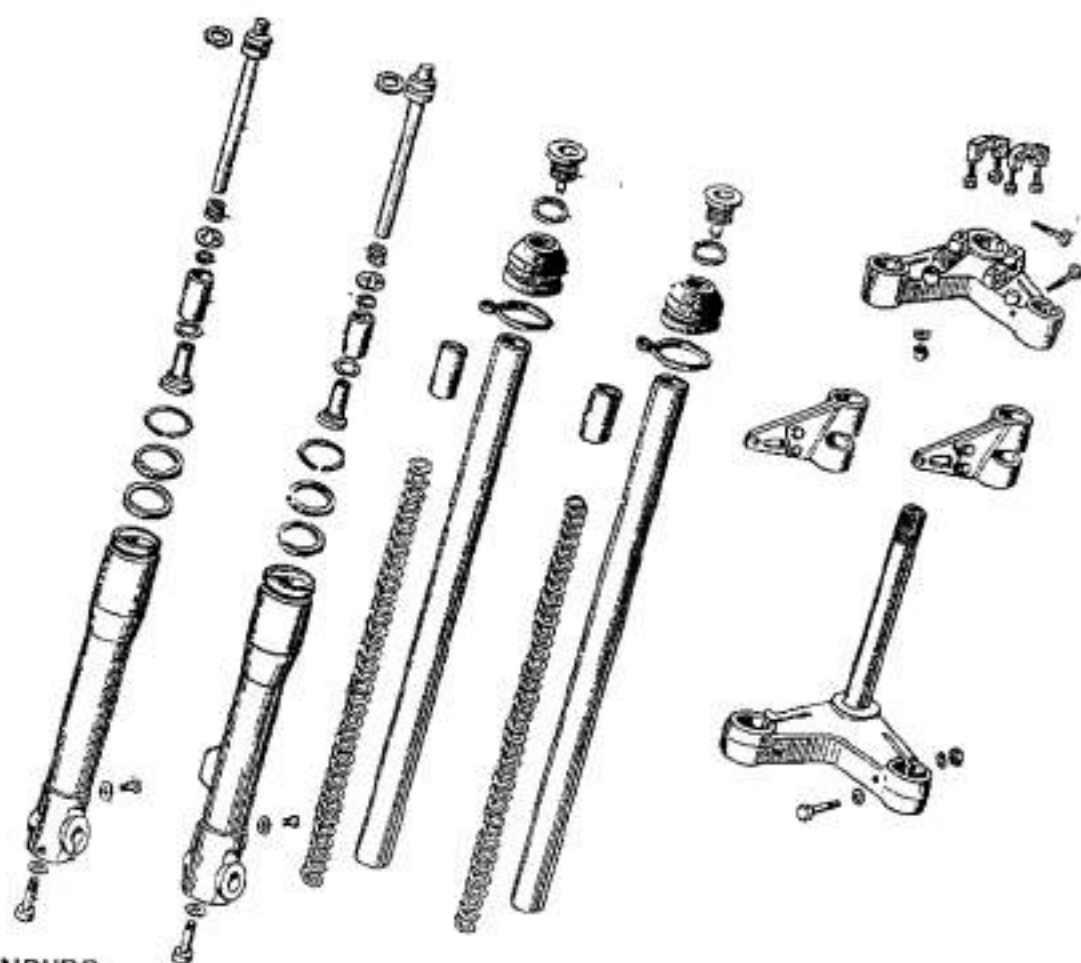

125 ENDURO

13 ELECTRICAL EQUIPMENT

The electrical equipment consists of a magneto flywheel, a battery (for 125 ENDURO), a spark plug, and a lighting system.

13.1 BATTERY 125 ENDURO

The battery is a 6V type with 9Ah capacity. It is charged by the magneto alternator.

To remove the battery take away the R/H number plate after undoing the screws, detach the electric wiring (positive and negative) and unhook the straps; then take out the battery from its housing.

Putting a dry charge battery into service (fig. 63) New battery

1 Remove seals and plugs and introduce in each cell sulphuric acid for batteries with a specific gravity $1.25 = 30^{\circ}$ Bé with a temperature of not less than 15°C , till the level is 5 to 10 mm over the top of the plate separators or the splashguard.

2 Let the battery rest for two hours.

3 Charge the battery at an intensity equal to about 1/10th of its capacity until the current intensity rate of the acid is about $1.27 = 31^{\circ}$ Bé and such rate has remained constant for at least 3 consecutive hours of charging. Normally, 6-8 hours charge are sufficient.

4 At the end of the charge, top up the acid, plug up and clean accurately.

Servicing the battery under service conditions

1 The electrolyte level should always cover the separators. To top up, use distilled water. Never add sulphuric acid.

2 If too frequent water additions are required, have the electrical system checked over as the battery works in an overcharged condition and will deteriorate quickly.

3 If the battery discharges quickly, the electrical system should also be checked over.

4 In case new or second hand batteries are left unused for fairly long periods of time, it is a good rule to charge them every month.

5 Always keep the battery terminals spotlessly clean and smeared with neutral vaseline.

6 Always keep the top battery cover dry, avoid overflows of electrolyte which will reduce insulation and corrode the battery bracket.

N.B. - If the batteries are used in tropical climates (average temperature over 33°C) it is recommended to reduce the acid gravity to 1.230 kg/l.

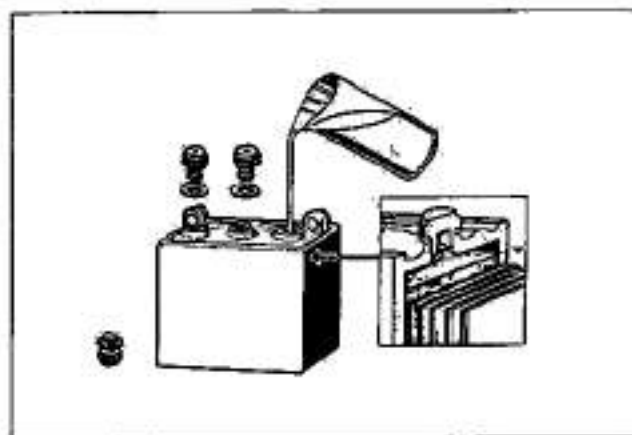

63

13.2 IGNITION

MOTORELLA G2 KS - G2 Elle - G2 with pedals

Adjusting and lubricating the rotor (fig. 64)

Every 5000 km lightly moisten cam felt pad «A» contacting the rotating part of the magneto fly-wheel with a few drops of engine oil. Check the contacts «B» gap (with the flywheel rotating cam lobe at max height) which must be of 0.40 mm, if the gap is more or less the indicated distance carry out the adjustment operating as follows:

- loosen by half turn the screw «C» fixing contact holder and by means of a screw driver move the contact breaker plate from «D» arrow position to obtain the correct gap; re-tighten screw «C» and re-check the adjustment.

Note

1 If contacts «B» are damaged there will be a faulty ignition. Ensure that the contacts are cleaned and plane, if necessary clean them with a petrol soaked rag.

2 If the contacts are dirty with oil there will be:
A a black coloration of contact and rapid consumption;

B deposits on the contacts with faulty ignition.

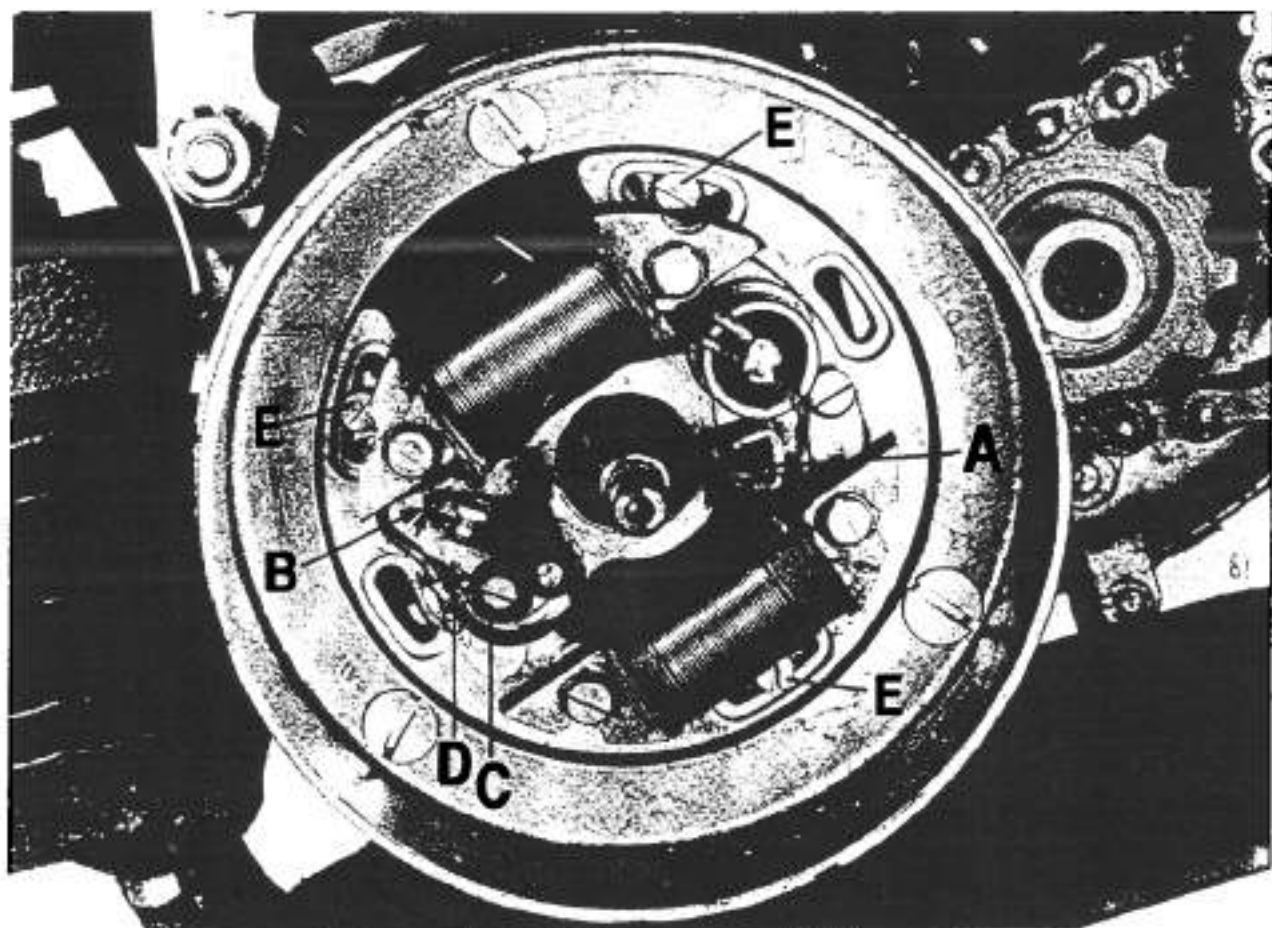

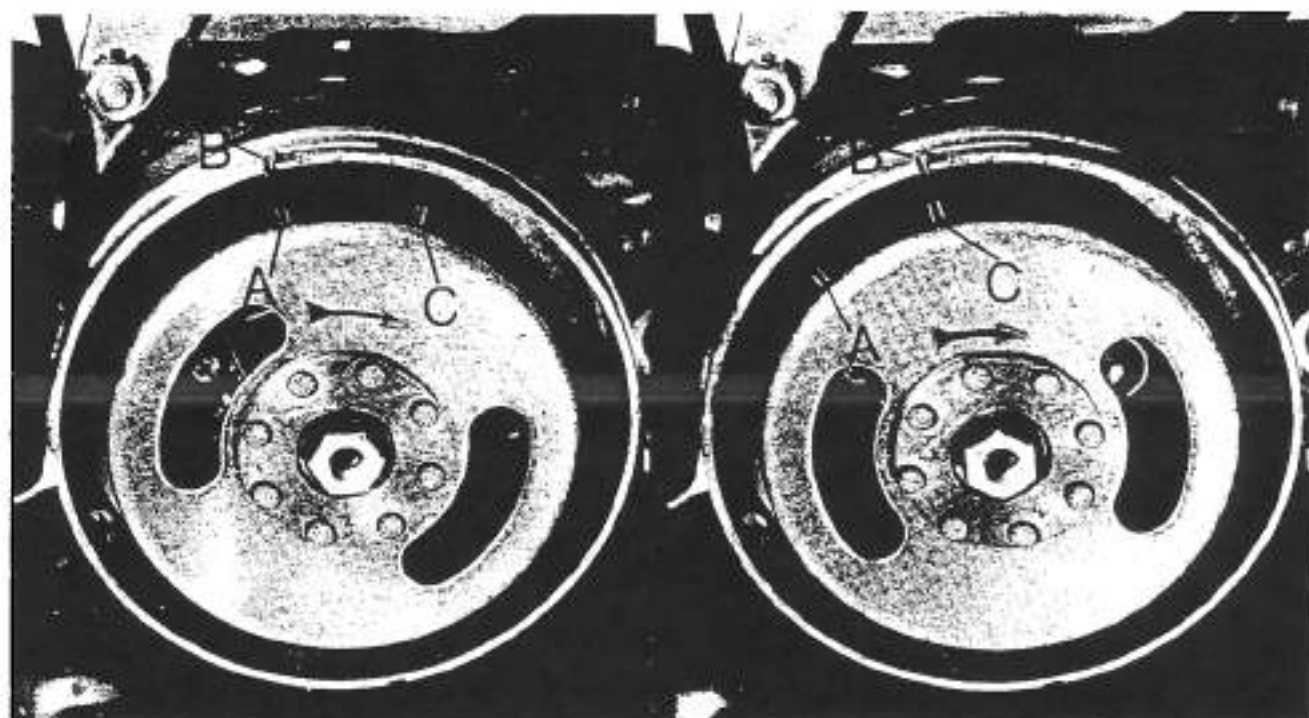

65

Adjusting the ignition

To adjust the ignition operate as follows:

- rotate in anticlockwise direction flywheel cover and slip it off;
- rotate the flywheel in clockwise direction till mark «A» on the rotating part is in line with mark «B» stamped on the crankcase cover (see fig. 65); at this point the piston is at its T.D.P.;
- connect Tester «C» cables (see fig. 66): cable «A» to the supply cable of the magneto flywheel; cable «B» to the engine ground;
- rotate the flywheel in anticlockwise direction till mark «C» on the rotating part of the flywheel is in line with mark «B» (see fig. 65) on the crankcase; at this point if everything is correct the Tester «D» pointer of fig. 66 moves in clockwise direction; this indicates that the ignition occurs exactly at the right moment, on the contrary it is necessary to loosen the three screws «E» of fig. 64 fixing the rotor plate to the crankcase and to turn this latter to the right or to the left till marks «B» and «C» of fig. 65 will be perfectly aligned when pointer «D» of Tester «C» of fig. 66 begins moving.

N.B. - Mark «C» of fig. 65 is at 29° before T.D.P. (mark «A») that corresponds to 27.5 mm on the outside of the flywheel.

For models Export 3V and Magnum 3V the ignition timing reference is at 28° before T.D.P. (O) corresponding to 25.2 mm measured on the outside of the flywheel.

Regarding the ignition adjustment and control for models 50 Turismo - Cross - 50 Magnum - 125 Turismo - 125 Enduro, the same procedure is valid, bearing in mind that the rotating direction of these engines is the contrary (sinistrorse from the flywheel side) see fig. 67 and that the ignition timing reference is at 20° before T.D.P. (O) corresponding to 19 mm measured on the outside of the flywheel.

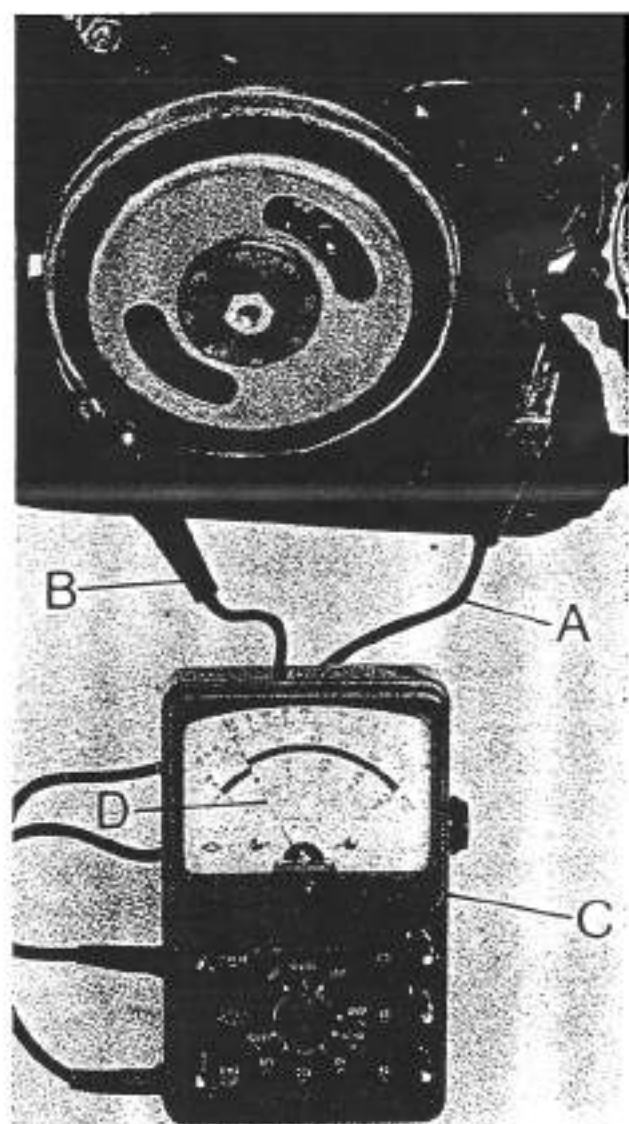

66

71

67

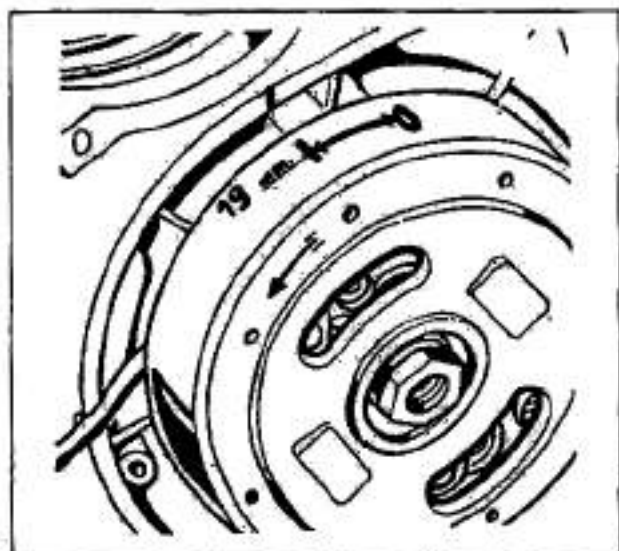

Spark plug (fig. 68)

A good performance of the engine depends also on the spark plug. A spark plug in bad conditions will not spark correctly and combustion will be poor. It is therefore advisable to check and clean periodically the spark plug and to adjust the points gap.

1 It is recommended to clean the spark plug with petrol and a wire brush, using a needle for the inner part.

2 After this operation check the points gap which must be of 0.5 mm. This adjustment is made acting on ground point.

3 The recommended spark plugs are:

- for Motorella and 50 5V: AC 44 XL - Bosch W 145 T2;
- for G2 Elle, G2 KS, G2 with pedals: AC 44F, Bosch W145 T1;
- for Export 3V, Magnum 3V: AC 42 XL, Bosch W240T2, Champion N3, Lodge 3HLN;
- for 125 T, 125 Enduro: AC 43 XL, Bosch W225 T2, Champion N4, Lodge 2HLN.

4 In re-fitting the spark plugs ensure they are started by hand for a few turns, completing then the operation with the special wrench.

68

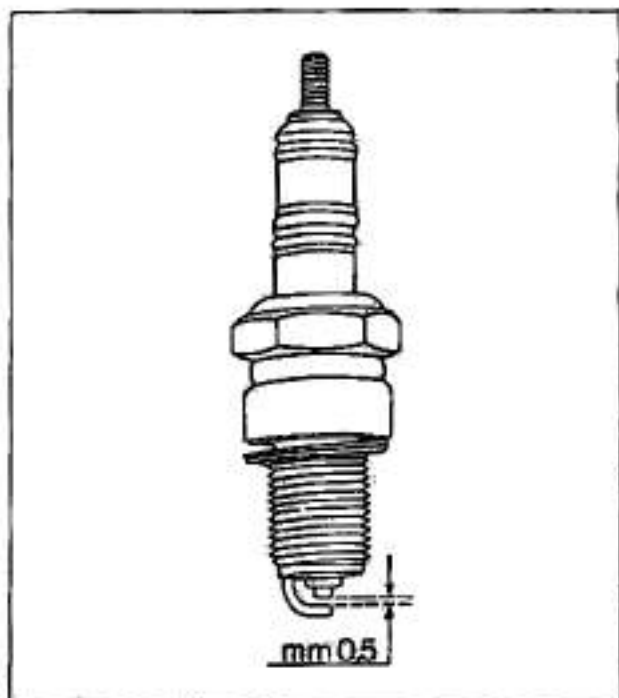

13.3 LIGHTING SYSTEM

Headlight bulb replacement

MOTORELLA - G2 KS - G2 Elle - G2 with pedals - MAGNUM 3V - EXPORT 3V

Undo the screws fixing the housing half upper part, lift this latter and replace the bulb. Once the replacement made refit the housing half and fix it with the screws.

**50 TURISMO - CROSS - MAGNUM
125 TURISMO - 125 ENDURO**

Undo the screw on the lower part of the rim and the two screws for mod. Cross. Remove the optical group or diffractor, slip off the bulb and replace it.

Tail light bulb replacement

Loosen the screws securing the reflex reflector to the tail light body.

Push the bulb inside, at the same time turn and take it off the holder.

Indicators lights for 125 Turismo - 125 Enduro

Loosen the screws securing the reflex reflector to the direction light housing.

Push the bulb inside, at the same time turn and take it off the holder.

In re-fitting the reflectors, screw in uniformly and moderately to prevent breakages of the reflectors same.

69

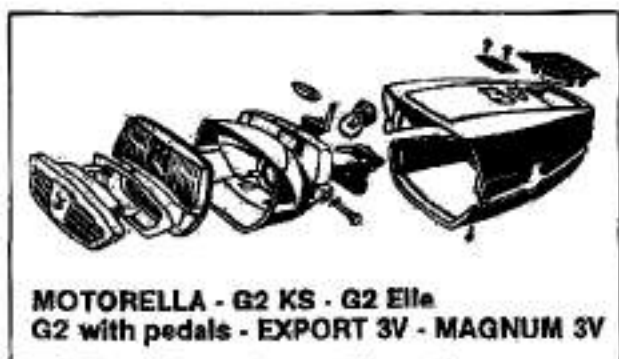

**Bulbs for Motorella - G2 KS - G2 Elle
G2 with pedals - Export 3V - Magnum 3V
50 Turismo - CROSS - MAGNUM**

Headlight

- town light (bulb 6V - 15W)
- high beam (bulb 6V - 15W)

Tail light

- parking light (bulb 6V - 5W)

125 TURISMO

Headlight

- high and low beam (bulb 6V - 35/35W)
- parking light (bulb 6V - 5W)

125 ENDURO

- high and low beam (bulb 6V - 25/25W)
- parking light (bulb 6V - 3W)

125 TURISMO - 125 ENDURO

Tail light

- parking and stop light (bulb 6V - 5/18 W)

Direction lights

- (bulb 6V - 10W)

Headlight beam adjustment (fig. 75)

For safe riding and not to trouble crossing riders, the headlight beam has always to be kept at correct height.

Vertical setting is adjusted by undoing the two fixing screws and shifting the headlight by hand.

At distance «A» of 10 m the centre of the high beam must not be over height «B» (bike not on the stand and rider on the saddle) of:

- 533 mm for Motorella
- 673 mm for G2 KS - G2 Elle
- 655 mm for G2 with pedals
- 603 mm for Magnum 3V
- 652 mm for Export 3V
- 729 mm for 50 Turismo
- 742 mm for Cross
- 568 mm for Magnum
- 749 mm for 125 Turismo
- 814 mm for 125 Enduro

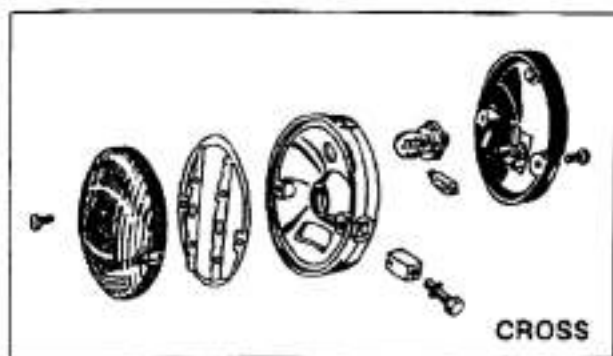

71

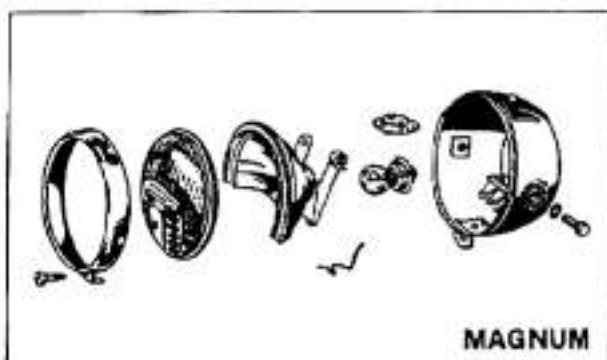

72

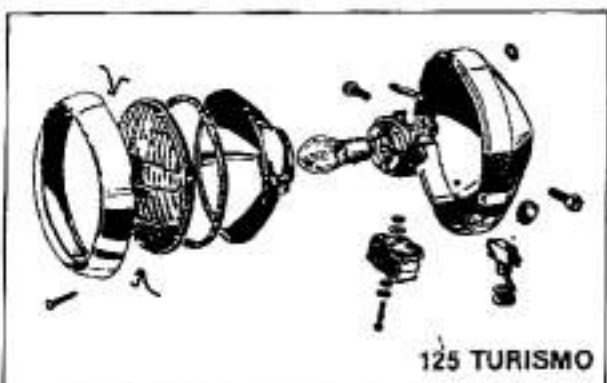

73

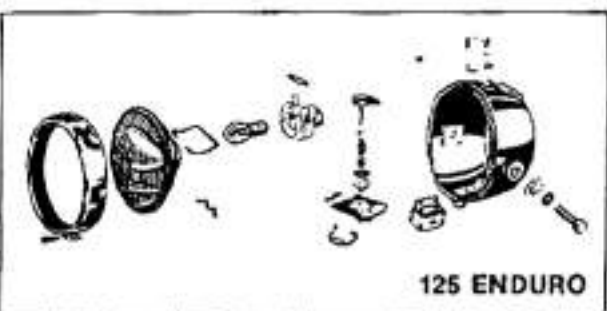

74

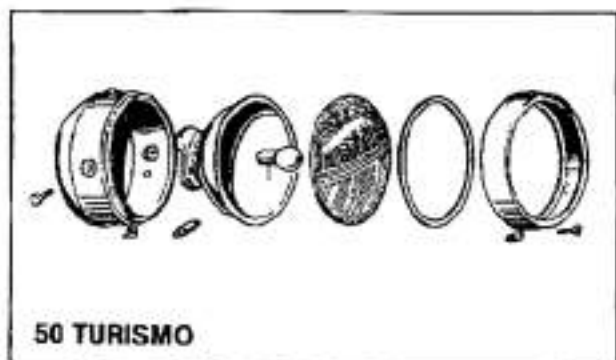

70

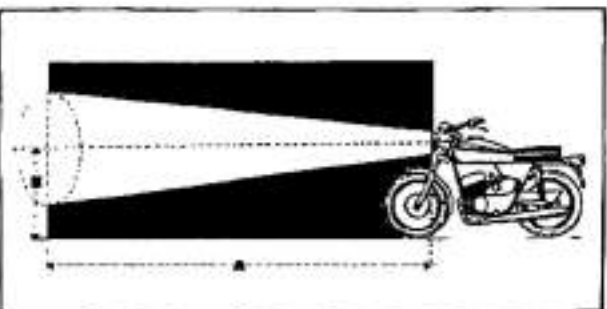

75

14 WIRING DIAGRAM

14.1 G2 ELLE

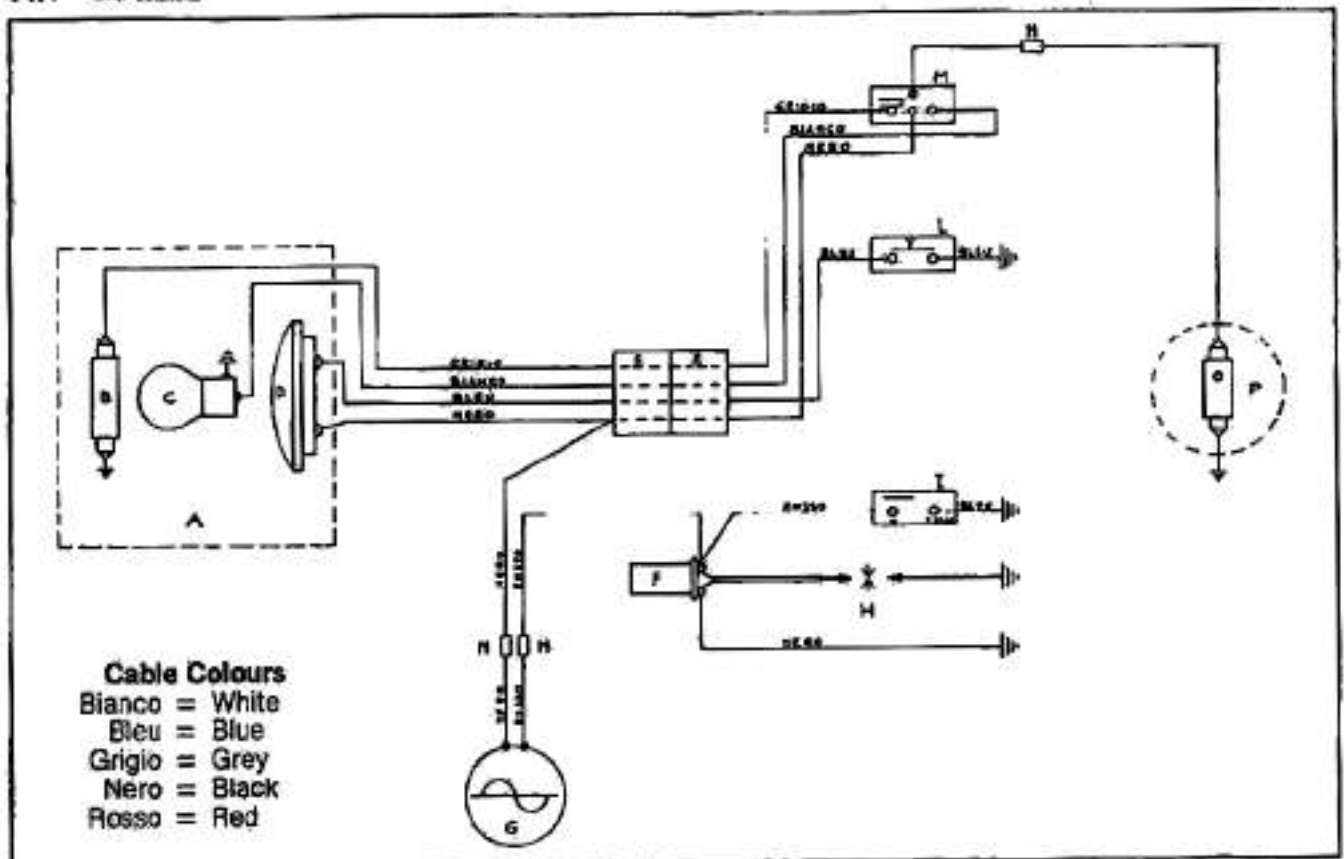

76

14.2 MOTORELLA - G2 KS - G2 with pedals MAGNUM 3V - EXPORT 3V

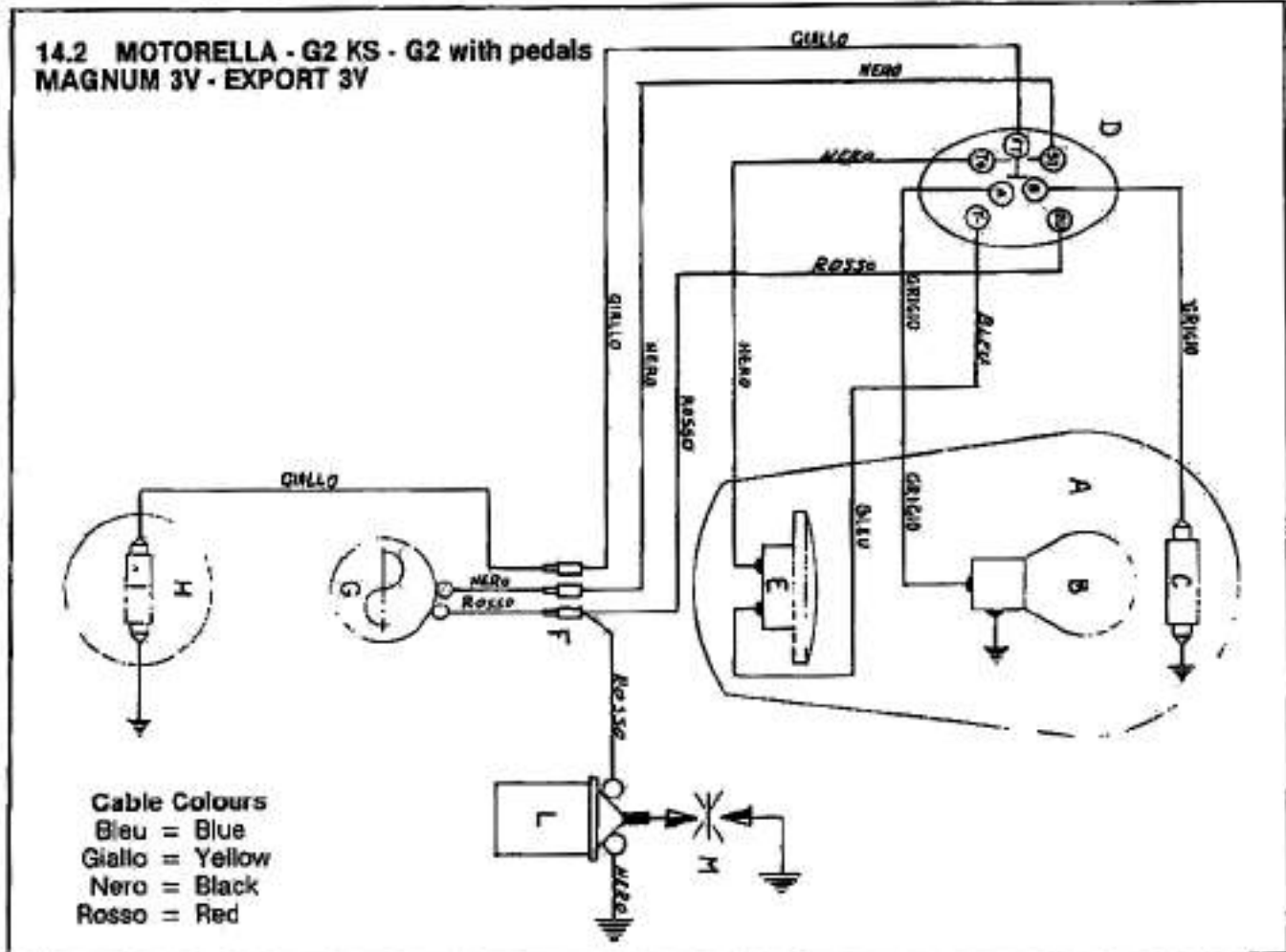

76/1

14.3 50 TURISMO

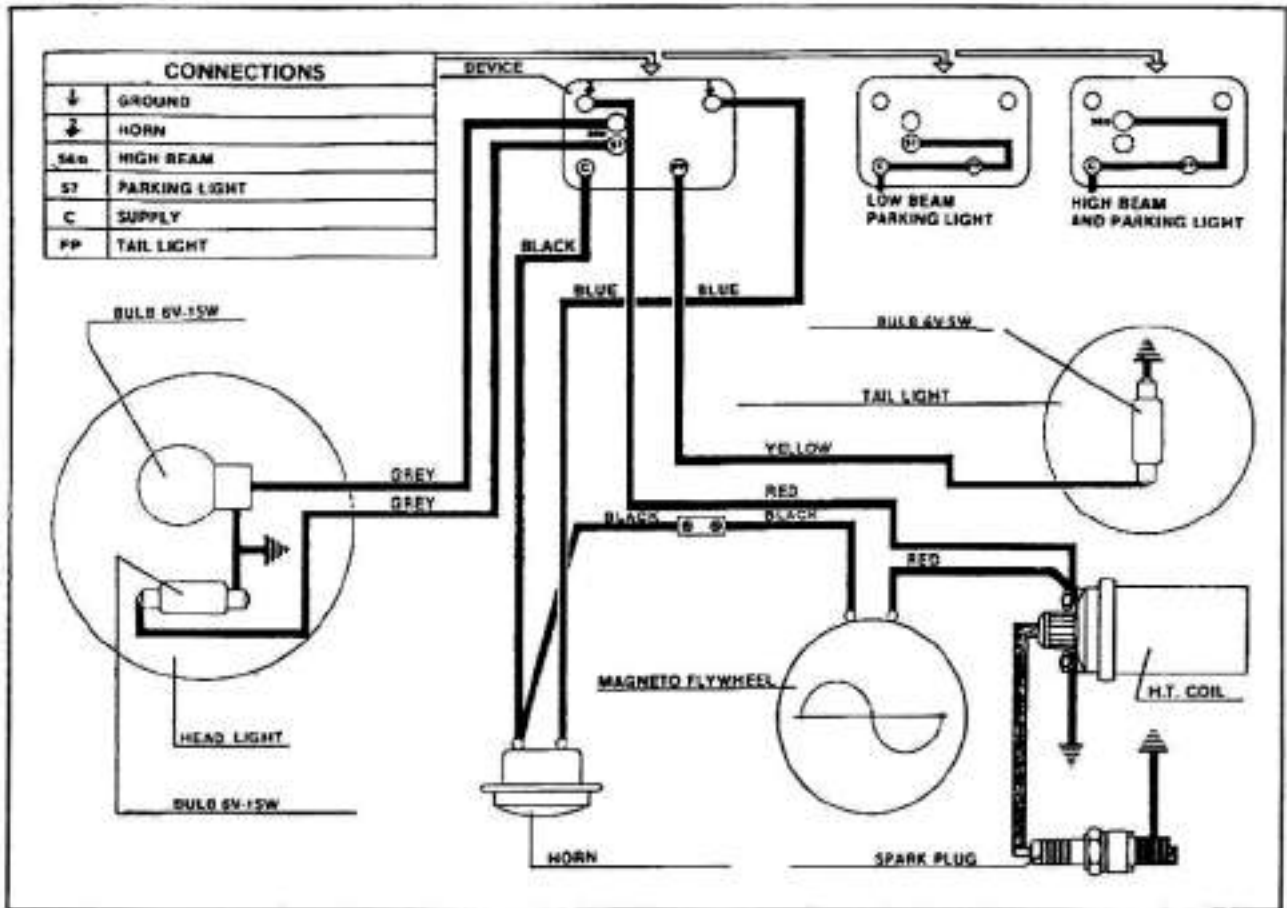

77

14.4 CROSS

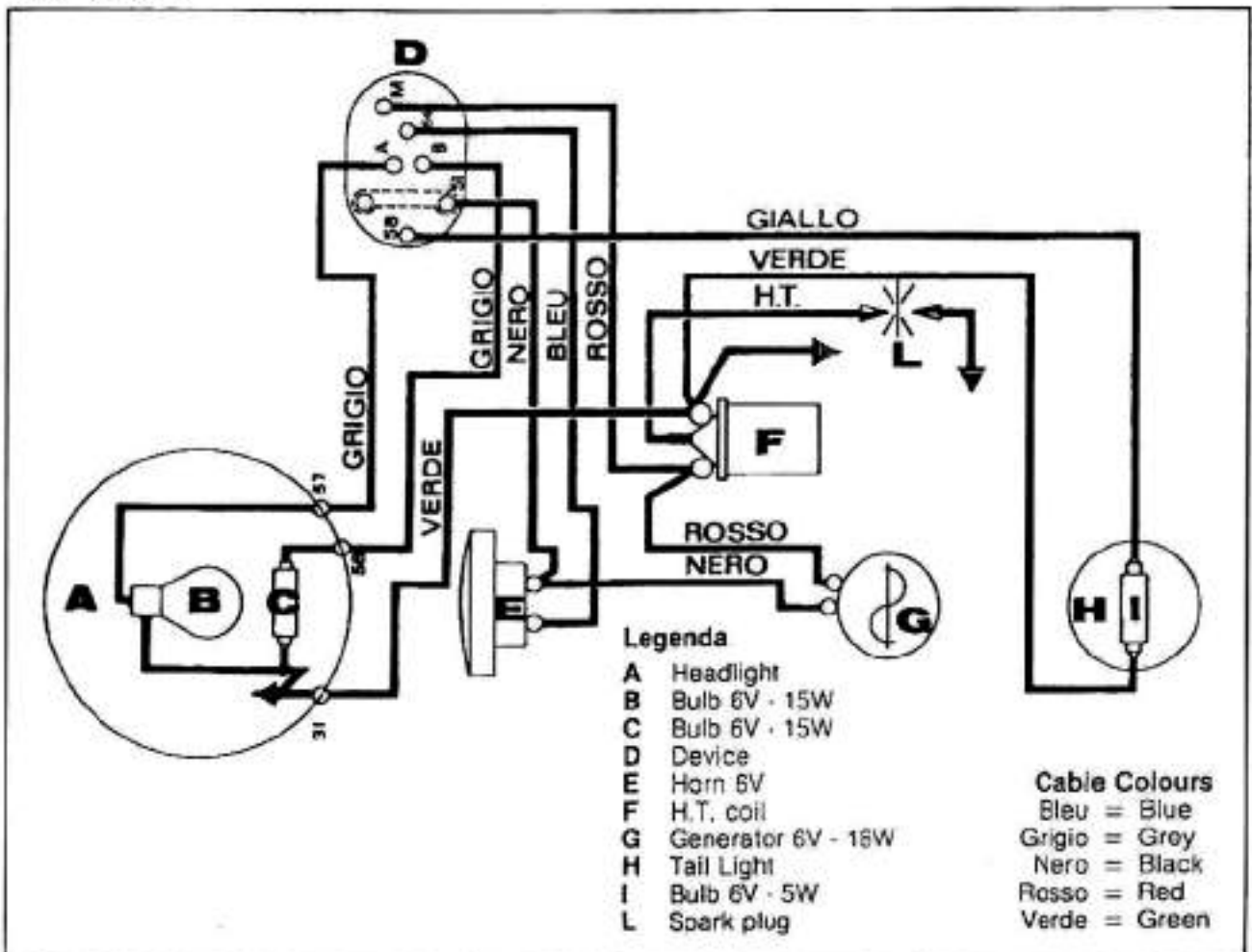

76

14.5 MAGNUM

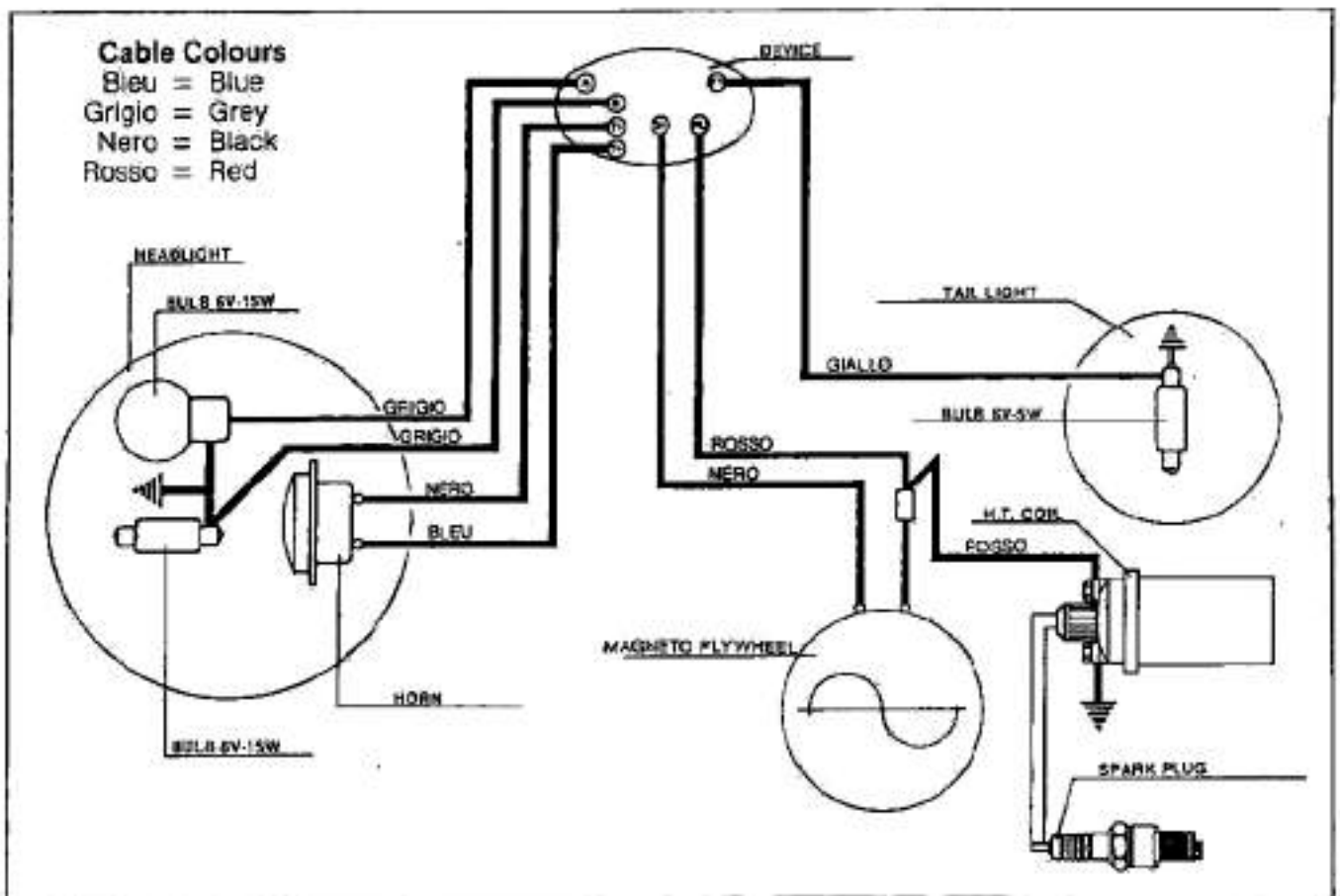

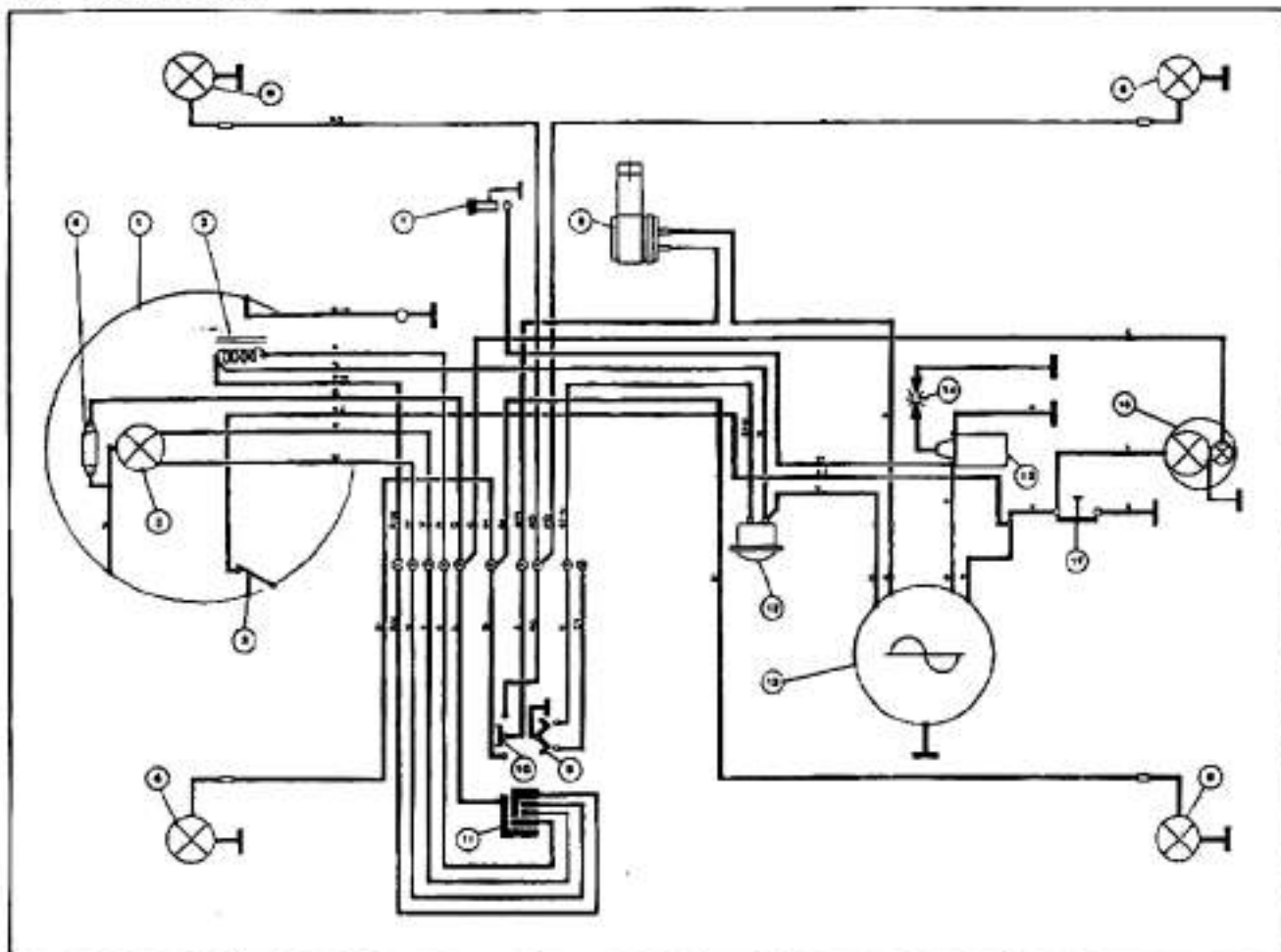

80

Legenda

- 1 Headlight
- 2 Impedance
- 3 Bulb 6V-35/35W
- 4 Bulb 6V-5W
- 5 Emergency, stop
- 6 Indicator light 6V-10W
- 7 Engine stop button
- 8 Intermittence
- 9 Horn control
- 10 Indicator lights switch
- 11 Lights switch
- 12 Horn
- 13 Magneto flywheel
- 14 Spark plug
- 15 H.T. coil
- 16 Tail light 6V -5/18W
- 17 Stop light switch

Cable colours

- A = Orange
- G = Yellow
- M = Brown
- N = Black
- R = Red
- V = Green
- AZ = Light blue
- BI = White
- GR = Grey
- RO = Pink
- VI = Violet
- A-N = Orange-Black
- BI-N = White-Black
- G-N = Yellow-Black
- R-N = Red-Black

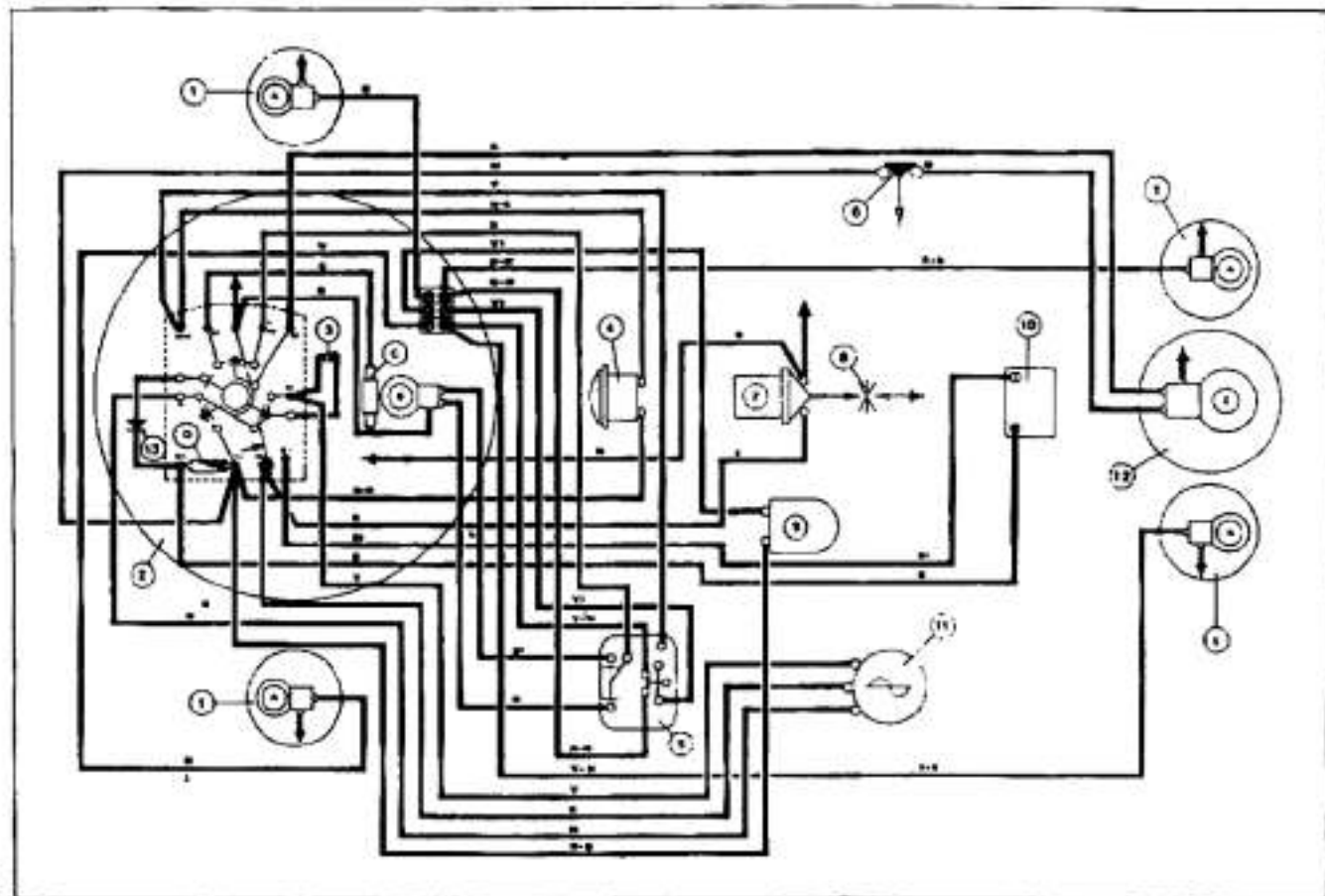

81

Legenda

- 1 Indicator lights
- 2 Headlight
- 3 Impedance
- 4 Horn
- 5 Switch
- 6 Stop light switch
- 7 Coil
- 8 Spark plug
- 9 Intermittence 6V-25W
- 10 Battery
- 11 Flywheel-magneto
- 12 Tail light
- 13 Rectifier
- A Bulb 6V · 10W
- B Bulb 6V · 25/25 W
- C Bulb 6V · 3W
- D Fuse 15A
- E Bulb 6V · 5/18 W

Cable colours

- G = Yellow
- M = Brown
- N = Black
- R = Red
- V = Green
- BI = White
- VI = Violet
- B = Blue
- V-N = Green-Black
- R-N = Red-Black
- N-B = Black-Blue